

**Rescue Union School District
2390 Bass Lake Road, Rescue, California 95672**

**BOARD OF TRUSTEES
REGULAR MEETING MINUTES**

Tuesday, March 13, 2018 - 6:30 p.m. Open Session (Closed Session at 5:30 p.m.)
Rescue District Office Board Room

DISTRICT MISSION

Rescue Union School District, in partnership with families and the community, is dedicated to the success of every student by providing a challenging, comprehensive, and quality education in a safe environment in which all individuals are respected, valued, connected, and supported.

ITEM	ITEM DESCRIPTION
CALL TO ORDER:	Board president will call the meeting to order at 5:30 p.m.
ROLL CALL:	<ul style="list-style-type: none"> ✓Nancy Brownell, President ✓Kim White, Vice President ✓Suzanna George, Clerk ✓Stephanie Kent, Member ✓Tagg Neal, Member ✓Cheryl Olson, Superintendent and Board Secretary ✓Sean Martin, Assistant Superintendent of Business Services <li style="padding-left: 20px;">Dave Scroggins, Assistant Superintendent of Curriculum and Instruction
PUBLIC COMMENT:	There were no public comments concerning items on the Closed Session Agenda.
CLOSED SESSION: District Conference Room	The Board adjourned to closed session at 5:31 p.m. to discuss matters of personnel, security, negotiations, student discipline, litigation, or other matters as authorized by Government Code Sections 3549.1, 54956.9, 54956.8, 54957, and 54957.6 and Education Code Sections 35146 and 48918.
Consideration of Confidential Student Related Matter	Interdistrict Appeal for Student #18/19-01.
Conference with Labor Negotiator	Discussion with the District's designated negotiators, Candice Harris and Sean Martin, regarding directions and issues in negotiations with Rescue Union Federation of Teachers (RUFT), California School Employees Association (CSEA), Confidential Staff, Administrative Management, and Yard Supervisors.
Conference with Real Property Negotiator	Conference with Real Property Negotiator pursuant to Government Code Section 54956.8, regarding: <ul style="list-style-type: none"> - Property: 3240 Bass Lake Road, APN 115-400-21-100 - Agency Negotiator: Sean Martin
OPEN SESSION:	Reconvene open session in the Board Room.
Welcome	The Board president provided an introduction to Board meeting proceedings.
Flag Salute	A Jackson student led the flag salute.

1. Adoption of Agenda (Consideration for Action)	Trustee White moved and Trustee Neal seconded to approve the agenda as presented. The motion passed 5-0.
STUDENT SUCCESS / RECOGNITION:	
Jackson School	<p>Jackson School principal, Michele Miller provided a site update and presentation highlighting student successes.</p> <p>The Difference Maker award was presented to Kathy Kelleher, Teacher, Daniel Royer, Lead Custodian and student Ben Ramsey for his inspirational reading accomplishment of 5,739, 361 words!</p>
REPORTS AND COMMUNICATION:	
Report from Closed Session	Board president reported no action taken in closed session.
2. Superintendent's Report (Supplement)	<p>Superintendent Olson reported it has been another busy month with the end of the second trimester, report cards and many events across the District. We are now gearing up for SBAC testing, Open House events, and programs. This Friday, is the International Festival from 5:00 to 7:00 p.m. hosted by Pleasant Grove School. It will feature multicultural performances, activities for kids, 5 food trucks and an evening of celebrating diversity and culture. We are thankful to Amy Bohren for taking the lead on this and all the people who help put this together.</p> <p>This past month, and particularly in light of the Florida tragedy, the District has been meeting with the Sheriff's Department, Office of Emergency Services and CHP for input on our site and district emergency plans. Also the Superintendent, Phil Jones, MO Coordinator, and Larry Garcia, Information Technology Manager attended a training put on by OES and our administrators will go through this training as well. Walk throughs are scheduled at each site and the Sheriff's Department and the Fire Department will be participating, using their eyes as a lens to review our protocols and procedures. In addition, tomorrow we have a few of our sites participating in age appropriate activities to promote friendship and kindness. We are proud of our students for taking initiative to be part of a solution and wanting to be sure that every student feels connected to school. The Superintendent also reported that Dave Scroggins, Assistant Superintendent of Curriculum and Instruction, Larry Garcia, Information Technology Manager, and Principals, Hope Migliaccio and Bruce Peters are all attending the Community Forum on School Safety this evening, hosted by the EDUHSD.</p>
3. Department Updates: Facilities	<p>The Board will receive updates on current activities within these departments.</p> <p>Assistant Superintendent of Business Services, Sean Martin presented a brief facilities update. Currently, the furniture options for the new Marina Village two-story classroom are being finalized. Staff members who will be using the classrooms met with vendors to discuss options. Right now one of the main access points for the campus is closed off in order for construction to continue and student safety is being closely monitored. The Interior work is progressing, the windows are in and the building is completely sealed on the outside.</p>

	<p>The water intrusion in the multipurpose room at Marina has been assessed. We had an engineer review the damage, the building is structurally sound and fortunately the repairs will not be as significant as we originally determined. It is still a large project and the required repairs will be completed over the summer.</p> <p>Site walks for the Jackson roof replacements occurred last week with contractors, and bid openings will be next week. This project will also be completed over the summer</p>												
<p>PUBLIC COMMENTS:</p>	<p>Public comments were heard from:</p> <table border="1" data-bbox="670 468 1476 537"> <tr> <td data-bbox="670 468 966 537">Sheila Fruge, parent</td> <td data-bbox="966 468 1476 537">RE: Special Education</td> </tr> </table>	Sheila Fruge, parent	RE: Special Education										
Sheila Fruge, parent	RE: Special Education												
<p>GENERAL:</p>													
<p>4. Interdistrict Attendance Appeal (Supplement) (Consideration for Action) Superintendent</p>	<p>The Board will consider the interdistrict attendance transfer appeal for Student #18/19-01.</p> <p>Trustee George moved and Trustee Kent seconded to approve the appeal for Student #18/19-01 to Buckeye School District for the 2018-2019 school year. The motion passed 4-1. Ayes: Trustee Kent, George, White and Brownell Noes: Trustee Neal</p>												
<p>5. Naming of Marina Village Field (Supplement) (Consideration for Action) Superintendent</p>	<p>The Board will receive the nominations reviewed by the Ad Hoc Committee regarding the naming of the Marina Village field.</p> <p>The Superintendent reviewed the process for the Ad Hoc committee and presented the four out of five names that were determined to meet the established criteria. Discussion revolved around not only naming the field but also looking at possibly naming the new building at Marina Village as well. Several audience members (listed below) addressed the Board.</p> <p>Endorsements were heard from:</p> <table border="1" data-bbox="670 1325 1476 1818"> <tr> <td data-bbox="670 1325 1096 1388">Heidi Hannaman Parent and former Marina student</td> <td data-bbox="1096 1325 1476 1388">RE: Endorsement for Erin Hague and Tony Deville</td> </tr> <tr> <td data-bbox="670 1388 1096 1478">John Hidahl Supervisor District 1 and former parent</td> <td data-bbox="1096 1388 1476 1478">RE: Endorsement for Tony DeVille</td> </tr> <tr> <td data-bbox="670 1478 1096 1568">Duane Heggly Community Member</td> <td data-bbox="1096 1478 1476 1568">RE: Endorsement for Tony DeVille</td> </tr> <tr> <td data-bbox="670 1568 1096 1659">Nicole Nesbit-Dolder Parent and former Marina Village student</td> <td data-bbox="1096 1568 1476 1659">RE: Endorsement for Erin Hague</td> </tr> <tr> <td data-bbox="670 1659 1096 1749">Susie Laird Community Member and former parent</td> <td data-bbox="1096 1659 1476 1749">RE: Endorsement for Tony DeVille</td> </tr> <tr> <td data-bbox="670 1749 1096 1818">Susan Parker Parent</td> <td data-bbox="1096 1749 1476 1818">RE: Endorsement to honor all four names</td> </tr> </table>	Heidi Hannaman Parent and former Marina student	RE: Endorsement for Erin Hague and Tony Deville	John Hidahl Supervisor District 1 and former parent	RE: Endorsement for Tony DeVille	Duane Heggly Community Member	RE: Endorsement for Tony DeVille	Nicole Nesbit-Dolder Parent and former Marina Village student	RE: Endorsement for Erin Hague	Susie Laird Community Member and former parent	RE: Endorsement for Tony DeVille	Susan Parker Parent	RE: Endorsement to honor all four names
Heidi Hannaman Parent and former Marina student	RE: Endorsement for Erin Hague and Tony Deville												
John Hidahl Supervisor District 1 and former parent	RE: Endorsement for Tony DeVille												
Duane Heggly Community Member	RE: Endorsement for Tony DeVille												
Nicole Nesbit-Dolder Parent and former Marina Village student	RE: Endorsement for Erin Hague												
Susie Laird Community Member and former parent	RE: Endorsement for Tony DeVille												
Susan Parker Parent	RE: Endorsement to honor all four names												

	Trustee George moved to table this item until the April 10, 2018 Regular Board meeting and amended the item to include consideration of also naming the new Marina Village building. Trustee Neal seconded the motion. The motion passed 5-0.		
6. School Safety Resolution #18-05 (Supplement) (Consideration for Action) Superintendent	The Board will consider approval of School Safety Resolution #18-05 regarding our obligations as the stewards of California schools to be vigilant where security is concerned, diligent in our attention to positive school culture and unrelenting in our advocacy for policies that increase student safety. Comments were heard from: <table border="1" data-bbox="669 499 1477 535"> <tr> <td>Kennedy Rivers, Parent</td> <td>RE: Student safety</td> </tr> </table> Trustee White moved and Trustee George seconded to approve Resolution # 18-05 School Safety. The motion passed 5-0.	Kennedy Rivers, Parent	RE: Student safety
Kennedy Rivers, Parent	RE: Student safety		
7. 2018 CSBA Delegate Assembly Election (Supplement) (Consideration for Action) Superintendent	CSBA elects their Delegate Assembly annually and delegates serve two-year terms. The Board as a whole may cast one vote for one candidate. Administration recommends the Board select a CSBA Delegate Assembly candidate.		
BUSINESS AND FACILITIES:	These items are provided for Board information, discussion, and/or action.		
8. Second Interim Budget Report (Supplement) (Consideration for Action) Assistant Superintendent of Business Services	The Board will receive a report on the District's Second Interim Report. District administration recommends approval of a positive certification for the Second Interim Budget Report. Trustee Kent moved and Trustee George seconded to approve the Second Interim Budget as presented. The motion passed 5-0.		
9. Bass Lake Property – Follow Up (Supplement) (Information Only) Assistant Superintendent of Business Services	The Board will receive follow up information regarding the Bass Lake Property. The Board directed Sean Martin to move forward with the process of notifying the appropriate agencies regarding the surplus of property according to the Naylor act.		
10. Public Hearing – Surplus Instructional Materials (Supplement) (Hearing/Consideration for Action) Assistant Superintendent of Business Services	In compliance with BP 3270, the District will: <ul style="list-style-type: none"> Hold a public hearing regarding the disposal of surplus instructional materials. The public notice has been posted for the appropriate 60-day period. OPEN PUBLIC HEARING: 9:08 p.m. CLOSE PUBLIC HEARING: 9:09 p.m. Consider action to declare items on the attached surplus list and dispose of by donation, destruction or sale Trustee George moved and Trustee Neal seconded to surplus the listed instructional materials. The motion passed 5-0.		

PERSONNEL:	
<p>11. Resolution #18-06 Reduction of Hours/Elimination of Positions - Certificated Personnel</p> <p>(Supplement)</p> <p>(Consideration for Action)</p> <p>Director of Human Resources</p>	<p>Due to lack of work, and/or lack of funds, certain services now being provided by the District must be reduced for the 2018-2019 school year. District Administration recommends approval of Resolution #18-06.</p> <p>Trustee George moved and Trustee White seconded to approve Resolution #18-06, Reduction of Hours/Elimination of Positions Certificated Personnel.</p>
<p>12. Resolution #18-07 Reduction of Hours/Elimination of Positions – Classified Personnel</p> <p>(Supplement)</p> <p>(Consideration for Action)</p> <p>Director of Human Resources</p>	<p>Due to lack of work and/or lack of funds, certain services now being provided by the District must be reduced for the 2018-2019 school year. District Administration recommends approval of Resolution #18-07.</p> <p>Trustee George moved and Trustee White seconded to approve Resolution #18-07, Reduction of Hours/Elimination of Positions Classified Personnel. The motion passed 5-0.</p>
<p>13. Public Hearing Proposals for CSEA Negotiation Openers for 2017-2018</p> <p>(Supplement)</p> <p>(Hearing)</p> <p>Director of Human Resources</p>	<p>To comply with Government Code 3547, the Board is holding a public hearing for comment prior to the adoption of CSEA Negotiation Openers in 2017-2018.</p> <p>· OPEN PUBLIC HEARING: 9:11 p.m. CLOSE PUBLIC HEARING: 9:12 p.m.</p>
CURRICULUM AND INSTUCTION:	
<p>14. School Calendar Update – 2018-19</p> <p>(Supplement)</p> <p>(Information Only)</p> <p>Superintendent</p>	<p>The Board will receive an update on the progress of the school calendar for 2018-19.</p>
<p>CONSENT AGENDA:</p> <p>(Consideration for Action)</p>	<p>All matters listed under Consent Agenda are considered to be routine or sufficiently supported by prior or accompanying reference materials and information as to not require additional discussion. A motion as referenced below will enact all items.</p> <p>Item #16 pulled for separate vote.</p> <p>Trustee George moved and Trustee White seconded to approve the balance of the Consent Agenda. The motion passed 5-0.</p>
<p>15. Board Meeting Minutes</p> <p>(Supplement)</p>	<p>Minutes of February 13, 2018 Regular Board meeting.</p>
<p>16. Board Meeting Minutes</p> <p>(Supplement)</p>	<p>Minutes of February 27, 2018 Study Session.</p> <p>Trustee George moved and Trustee White seconded to approve the minutes of the February 27, 2018 Study Session. The motion passed 4-0 with one abstention.</p>

	Ayes: Trustee Neal, Kent, George and White Abstention: Trustee Brownell
17. District Expenditure Warrants (Supplement)	Warrants must regularly be presented to the Board of Trustees for ratification. Detailed warrant order listings are available at the District Office. The supplement reflects expenditures from 2/13/18 through 3/7/18.
18. District Purchase Orders (Supplement)	Purchase orders must regularly be presented to the Board of Trustees for ratification. The supplemental reflects expenditures from 2/8/18 through 3/7/18.
19. Personnel (Supplement)	Rescue Union School District's long-range goal is to recruit a diverse, high quality staff whose goals and philosophies are student focused. Periodically, changes in staffing occur due to need for additional positions, resignations, or requests for leaves of absence. All positions listed are within current budget allocations.
A. Classified Employment:	Megan Cone, IA Paraeducator, (.1554 FTE), Jackson, effective 2/20/18 Travis Curl, Yard Supervisor, (.3854 FTE), Lake Forest, effective 3/5/18 Kore Higuchi, Custodian, (.3750 FTE), Jackson, effective 2/26/18 Haley Mudd, Bus Driver, (.6563 FTE), Transportation, effective 2/27/18 Karrie Roberts, Yard Supervisor, (.4375 FTE), Rescue, effective 2/2/18 Laura Webster, Bus Driver, (.6250 FTE), Transportation, effective 3/12/18
Resignation:	Bonnie Baltazar, IA Paraeducator Bilingual, (.75 FTE), Green Valley, effective 3/2/18 Beth Brazil, IA Paraeducator, (.3750 FTE), Rescue, effective 2/23/18 Susan Hyde, Food Service Worker, (.4687 FTE), Green Valley, effective 2/13/18 Noelle Miller, IA Special Health Care, (.75 FTE), Marina Village, effective 3/7/18
20. Safe School Plans (Supplement)	The Board will consider approval of the Safe School Plans. These plans are updated each year and are developed with the involvement of school, community leaders, staff, parents and students.
21. Individual Service Agreement for Nonpublic School/Agency – Guiding Hands School, Inc. (Supplement)	The Rescue Union School District has a student whose needs require a nonpublic agency service. Based on the identified needs of this student, service through Guiding Hands School, Inc. is seen as the appropriate provider.
22. Audit Services (Supplement)	The District must confirm its arrangement for the annual audit by April 1. District administration recommends approval for Crowe Horwath LLP to provide audit services.

23. Agreement Regarding Allocation of School Mitigation Fees (Supplement)	The Board will consider approval of the renewal agreement with El Dorado Union High School District for allocation of school mitigation fees from July 1, 2018 to June 30, 2021.
24. Out-of-State Travel North State Spring Conference (Supplement)	The Board will consider the out-of-state travel for the Assistant Superintendent of Business Services and the Assistant Superintendent of Curriculum and Instruction to the ACSA North State Spring Conference being held in Reno, Nevada.
25. Consolidated Application (Supplement)	The District applies for Federal Categorical Program Funding on a yearly basis. The Application for Funding for the 2017-2018 year is submitted to the Board for approval
CLOSED SESSION:	The Board may reconvene to closed session as authorized by Government Code Sections 3459.1, 54956.9, 54956.8, 54957, and 54957.6 and Education Code Sections 35146 and 48918.
OPEN SESSION:	Reconvene open session.
REPORT FROM CLOSED SESSION:	The Board president will report any action taken in closed session.
ADJOURNMENT:	Trustee White moved to adjourn the meeting at 9:19 p.m.

Vendor/Addr	Remit name	Tax ID num	Deposit type	ABA num	Account num	Liq Amt	Net Amount
Req Reference	Date	Description	FD RESC Y OBJT GOAL	FUNC LC1	LOC2 L3 SCH T9MPS		

102582 (CONTINUED)

185105	PO-180071	02/23/2018	351686795	MARCH	2 01-0000-0-5690-0000-7200-080-0000-00-000	NN P	221.07	221.07
	PV-181183	02/23/2018	351686795	LF	01-1100-0-5633-1110-1000-028-0000-98-000	NN		339.26
	PV-181183	02/23/2018	351686795	GV	01-1100-0-5633-1110-1000-020-0000-90-000	NN		329.60
	PV-181183	02/23/2018	351686795	JK	01-1100-0-5633-1110-1000-021-0000-91-000	NN		530.94
	PV-181183	02/23/2018	351686795	LV	01-1100-0-5633-1110-1000-027-0000-97-000	NN		414.12
	PV-181183	02/23/2018	351686795	DO	01-0000-0-5633-0000-7200-080-0000-00-000	NN		165.41
	PV-181183	02/23/2018	351686795	RS	01-1100-0-5633-1110-1000-022-0000-92-000	NN		665.56
	PV-181183	02/23/2018	351686795	SPED	01-0000-0-5633-0000-7200-080-0000-00-000	NN		32.66
	PV-181183	02/23/2018	351686795	M&O	01-8150-0-5633-0000-8110-085-0000-00-000	NN		8.48
	PV-181183	02/23/2018	351686795	TRANS	01-0842-0-5633-0000-3600-083-0000-00-000	NN		8.47
	PV-181183	02/23/2018	351686795	TONER	01-0842-0-4300-0000-3600-083-0000-00-000	NN		4.99
	PV-181183	02/23/2018	351686795	TONER	01-8150-0-4300-0000-8110-085-0000-00-000	NN		4.99
	PV-181183	02/23/2018	351686795	TONER	01-0000-0-4300-0000-7200-080-0000-00-000	NN		4.99
	PV-181183	02/23/2018	351686795	TONER	01-9420-0-4300-1110-1000-020-9000-90-000	NN		4.99
TOTAL PAYMENT AMOUNT							5,511.71 *	5,511.71

000491/00 US POSTMASTER

PV-181210	03/07/2018	ROLL OF STAMPS		01-0842-0-5902-0000-3600-083-0000-00-000	NN		47.00	
TOTAL PAYMENT AMOUNT							47.00 *	47.00

104463/00 VISTA CHILD THERAPY LLC 680119946

185197	PO-180236	03/14/2018	INC PER J.Reed	1 01-6500-0-5806-5770-1180-063-0000-00-000	N6 C	1,000.00	0.00	
185197	PO-180236	03/14/2018	INC PER J.Reed	1 01-6500-0-5806-5770-1180-063-0000-00-000	N6 O	-1,928.75	0.00	
TOTAL PAYMENT AMOUNT							0.00 *	0.00

102998/00 WELLS FARGO FINANCIAL LEASING 421074725

185821	PO-180789	02/26/2018	5004628012	MARCH	1 01-0000-0-5690-1110-1000-081-0000-00-000	NN P	235.96	235.96
TOTAL PAYMENT AMOUNT							235.96 *	235.96

TOTAL BATCH PAYMENT 109,468.84 *** 0.00 109,468.84
TOTAL USE TAX AMOUNT 219.69

TOTAL DISTRICT PAYMENT 109,468.84 **** 0.00 109,468.84
TOTAL USE TAX AMOUNT 219.69

TOTAL FOR ALL DISTRICTS: 109,468.84 **** 0.00 109,468.84
TOTAL USE TAX AMOUNT 219.69

Number of checks to be printed: 59, not counting voids due to stub overflows.
Number of zero dollar checks: 6, will be printed.

Pursuant to Rescue Union School District policy, the El
Gorale County Superintendent of Schools is hereby
authorized and directed to issue individual warrants to the
payees named herein.

District Designer

3/14/18

Date

Vendor/Addr	Remit name	Description	Tax ID num	Deposit type	ABA num	Account num	Liq Amt	Net Amount
Req Reference	Date			FD RESC Y OBJT GOAL	FUNC LC1	LOC2 L3 SCH T9MPS		
104986/00	TPX COMMUNICATIONS							
	PV-181251	03/09/2018	101366211-0	01-0000-0-5901-0000-7600-081-0000-00-000	NN			1,566.47
	PV-181251	03/09/2018	101366211-0 ADJ	01-0000-0-8695-0000-0000-000-0000-00-000	NN			-514.40
				TOTAL PAYMENT AMOUNT		1,052.07 *		1,052.07
100070/00	ULMER, ELIZABETH							
	PV-181261	03/05/2018	SKYLINE PARK - 2 NIGHTS	01-4035-0-5200-1110-1000-135-0000-94-000	NN			60.00
				TOTAL PAYMENT AMOUNT		60.00 *		60.00
101567/00	VALLEY TRUCK & TRACTOR COMPANY							
	185057 PO-180211	02/27/2018	780812	1 01-0000-0-4300-0000-8210-084-0000-00-000	NN P		409.58	409.58
				TOTAL PAYMENT AMOUNT		409.58 *		409.58
001585/00	WESTERN PSYCHOLOGICAL SERVICES							
	185863 PO-180830	03/02/2018	WPS-203486	1 01-6500-0-4300-5001-3120-063-0000-00-000	NN F		55.45	55.77
				TOTAL PAYMENT AMOUNT		55.77 *		55.77
005634/00	YOUNGDAHL CONSULTING GROUP INC	680046553						
	185574 PO-180546	02/28/2018	63277	1 35-0000-0-6240-0000-8500-024-1032-00-000	N7 P		310.00	310.00
				TOTAL PAYMENT AMOUNT		310.00 *		310.00
				TOTAL BATCH PAYMENT		318,309.30 ***	0.00	318,309.30
				TOTAL USE TAX AMOUNT		40.95		
				TOTAL DISTRICT PAYMENT		318,309.30 ****	0.00	318,309.30
				TOTAL USE TAX AMOUNT		40.95		
				TOTAL FOR ALL DISTRICTS:		318,309.30 ****	0.00	318,309.30
				TOTAL USE TAX AMOUNT		40.95		

Number of checks to be printed: 81, not counting voids due to stub overflows.
 Number of zero dollar checks: 2, will be printed.

Pursuant to Rescue Union School District policy, the El
 Derado County Superintendent of Schools is hereby
 authorized and directed to issue individual warrants to the
 payee named herein.

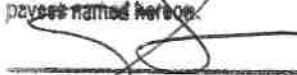
 District Designer

3/21/18
 Date

015 RESCUE UNION SCHOOL DISTRICT J87591
 KIP 3/28/18 #8041

ACCOUNTS PAYABLE PRELIST
 BATCH: 8041 KIP 3/28/18 #8041

APY500 L.00.12 03/27/18 15:41 PAGE 19
 << Held for Audit >>

Vendor/Addr Req Reference	Remit name Date	Description	Tax ID num	Deposit type FD RESC Y OBJT GOAL	ABA num FUNC LC1	Account num LOC2 L3 SCH T9MPS	Liq Amt	Net Amount
105420/00	STORMENT, JEANNA							
	PV-181274	03/23/2018 MILEAGE 3/15-3/23/18		01-0000-0-5200-0000-3140-089-0000-00-000	NN			24.20
			TOTAL PAYMENT AMOUNT			24.20 *		24.20
104464/00	SUMMITVIEW CHILD AND FAMILY		943181886					
	185397 PO-180371	02/28/2018 FEBRUARY 2018		1 01-6512-0-5811-5770-3110-063-0000-00-000	N6 P		693.00	693.00
			TOTAL PAYMENT AMOUNT			693.00 *		693.00
100357/00	THOMS, LISA							
	PV-181306	03/23/2018 SPELLING SITY-ONLINE SUB		01-9427-0-5806-1110-1000-027-0000-97-000	NN			60.75
			TOTAL PAYMENT AMOUNT			60.75 *		60.75
104582/00	VALENCIA, KATRIINA`							
	PV-181303	03/21/2018 LEARNING A-Z - ONLINE SUB		01-9427-0-5806-1110-1000-027-9000-97-000	NN			109.95
			TOTAL PAYMENT AMOUNT			109.95 *		109.95
			TOTAL BATCH PAYMENT			89,872.36 ***	0.00	89,872.36
			TOTAL USE TAX AMOUNT			33.73		
			TOTAL DISTRICT PAYMENT			89,872.36 ****	0.00	89,872.36
			TOTAL USE TAX AMOUNT			33.73		
			TOTAL FOR ALL DISTRICTS:			89,872.36 ****	0.00	89,872.36
			TOTAL USE TAX AMOUNT			33.73		

Number of checks to be printed: 86, not counting voids due to stub overflows.
 Number of zero dollar checks: 13, will be printed.

Pursuant to Rescue Union School District policy, the
 Dade County Superintendent of Schools is hereby
 authorized and directed to issue individual warrants to the
 payees named hereon.

Cheryl Olson 3/27/18
 District Designer

015 RESCUE UNION SCHOOL DISTRICT J88023
KIP 04/02/18 #8042

ACCOUNTS PAYABLE PRELIST
BATCH: 8042 KIP 04/02/18 #8042

APY500 L.00.12 03/29/18 12:40 PAGE 7
<< Held for Audit >>

Vendor/Addr Req Reference	Remit name Date	Description	Tax ID num	Deposit type FD RESC Y OBJT GOAL	ABA num FUNC LC1	Account num LOC2 L3 SCH T9MPS	Liq Amt	Net Amount
				TOTAL DISTRICT PAYMENT	338,110.64	****	0.00	338,110.64
				TOTAL USE TAX AMOUNT	107.14			
				TOTAL FOR ALL DISTRICTS:	338,110.64	****	0.00	338,110.64
				TOTAL USE TAX AMOUNT	107.14			

Number of checks to be printed: 37, not counting voids due to stub overflows.

Pursuant to Rescue Union School District policy, the El
Dorado County Superintendent of Schools is hereby
authorized and directed to issue individual warrants to the
payees named hereon.

Cheryl Olson 3/29/18
District Designee Date

01 GENERAL FUND

P.O.#	VENDOR NAME	DESCRIPTION	AMOUNT	SITE NAMES
180882	ABDO	LF Library Order	2,328.12	Lake Forest School
180896	AERIES SOFTWARE	Aeries Training	1,000.00	Marina Village School
180724	ALL CHARGED UP	Replacement Parts	326.00	Lakeview
180900	AVID CENTER	Summer Institute Registration	7,155.00	Pleasant Grove Middle School
180877	BARE BOOKS	Bare Books for LF PTC	808.17	Lake Forest School
180906	BEST BUY	Classroom speakers	1,647.75	Pleasant Grove Middle School
180903	BIO CORPORATION	PLTW supplies	77.32	Pleasant Grove Middle School
180899	BULK BOOKSTORE	4th Grade Books	611.33	Lakeview
180888	BUREAU OF EDUCATION & RESEARCH	BER NGSS Conference	259.00	Marina Village School
180907	CALIFORNIA MENTAL HEALTH ADVOC	Admin Travel- Mental Health	950.00	DISTRICTWIDE SERVICES
180904	CAROLINA BIOLOGICAL SUPPLY	7th grade Science	876.89	Pleasant Grove Middle School
180847	CDW-G	Chromebook - Larry	339.95	DISTRICTWIDE SERVICES
180848	CDW-G	Call Button Kit	80.44	DISTRICTWIDE SERVICES
180876	CDW-G	Projectors: 1-JS, 2-LF, 2- RS	2,944.01	DISTRICTWIDE SERVICES
180897	CDW-G	RSP Equipment	453.64	DISTRICTWIDE SERVICES
180855	CENTER FOR AUTISM AND RELATED	IEE FBA	1,500.00	DISTRICTWIDE SERVICES
180840	CREATIVE BUS SALES INC		5,321.61	Transportation
180870	DEMCO INC	Library Supplies	966.70	DISTRICTWIDE SERVICES
180909	DISCOUNT TWO WAY RADIO CORP	Handheld Radios	3,079.91	Pleasant Grove Middle School
180863	DJ CIRCLE ENTERTAINMENT INC	Dance Rental	600.00	Pleasant Grove Middle School
180841	EL DORADO COUNTY	WORKSHOP	450.00	DISTRICTWIDE SERVICES
180853	EL DORADO COUNTY	DO-ENVELOPES	219.86	Maintenance
180859	EL DORADO COUNTY	PBIS Referral Form-NCR	254.18	Green Valley School
180854	EL DORADO MUSICAL INST REPAIR	Instrument Repairs	92.00	Pleasant Grove Middle School
180861	ENTEK CONSULTING GROUP INC		3,160.00	Maintenance
180879	FERGUSON ENTERPRISES INC		2,010.94	Operations
180844	FLINN SCIENTIFIC INC	8th Grade Science Mtls	327.28	Pleasant Grove Middle School
180852	FOLLETT SCHOOLS SOLUTIONS INC	Book order for Library	1,506.89	Jackson School
180869	FOLLETT SCHOOLS SOLUTIONS INC	Birthday Books	439.44	Lakeview
180871	FOLLETT SCHOOLS SOLUTIONS INC	Birthday Books	638.22	Lakeview
180872	FOLLETT SCHOOLS SOLUTIONS INC	Birthday Books	360.63	Lakeview
180873	FOLLETT SCHOOLS SOLUTIONS INC	Birthday Books	1,042.04	Lakeview
180874	FOLLETT SCHOOLS SOLUTIONS INC	Birthday Books	1,142.50	Lakeview
180875	FOLLETT SCHOOLS SOLUTIONS INC	Library Book Order	1,707.73	Green Valley School
180880	FOLLETT SCHOOLS SOLUTIONS INC	LF Library Order	882.54	Lake Forest School
180881	FOLLETT SCHOOLS SOLUTIONS INC	MV Awards/Honors Books	364.59	DISTRICTWIDE SERVICES
180883	FOLLETT SCHOOLS SOLUTIONS INC	PG Awards/Honors Books	250.11	DISTRICTWIDE SERVICES
180884	FOLLETT SCHOOLS SOLUTIONS INC	Spanish - Math Textbk Gr 8 -PG	100.82	DISTRICTWIDE SERVICES
180885	FOLLETT SCHOOLS SOLUTIONS INC	GV Barcodes	99.66	DISTRICTWIDE SERVICES
180032	GOOD YEAR		2,000.00	Transportation
180908	GRANITE DATA SOLUTIONS	head phones	567.89	Rescue School
180865	HARRIS CENTER FOR THE ARTS	Harris Center for the Arts	386.00	Green Valley School
180858	HCI AUDIOMETRICS	Audiometer Calibration	525.00	DISTRICTWIDE SERVICES
180889	J.W. PEPPER & SON INC	World Music BOOK/DVD	84.73	Marina Village School
180895	JOHN MCNAMEE COMPANY	PE Pacer Shirts	345.97	Marina Village School
180866	JONES SCHOOL SUPPLY CO INC	Honor Roll Bumper Stickers	231.51	Jackson School
180850	JUNIOR LIBRARY GUILD	Library Books	134.06	Lakeview
180893	JUNIOR LIBRARY GUILD	Subscription Renewal	219.94	Green Valley School
180892	KAESER & BLAIR INC.	Dog Tag Awards Library	451.00	Green Valley School
180851	MID AMERICA BOOKS	Library Books	552.62	Lakeview
180898	MONOPRICE INC	SUPPLIES	128.68	DISTRICTWIDE SERVICES

01 GENERAL FUND

P.O.#	VENDOR NAME	DESCRIPTION	AMOUNT	SITE NAMES
180846	MUSIC IN THE PARKS	Six Flags Band Festival	5,545.00	Pleasant Grove Middle School
180856	MYSTERY SCIENCE	science	499.00	Rescue School
180902	NASCO MODESTO	7th Grade Science	87.11	Pleasant Grove Middle School
180867	NCS PEARSON INC	Psych Supplies	219.90	DISTRICTWIDE SERVICES
180878	NILES BIOLOGICAL	Owl Pellets LF PTC	237.25	Lake Forest School
180842	NORTH STATE SPRING CONFERENCE	Registraton	349.00	DISTRICTWIDE SERVICES
180894	POSITIVE PROMOTIONS	Reading Counts Green Pencils	183.95	Green Valley School
180890	RISO PRODUCTS OF SACRAMENTO	Riso Supplies	299.76	Lake Forest School
180843	ROTARY CLUB OF EL DORADO HILLS	Membership	400.00	DISTRICTWIDE SERVICES
180886	SCHOOL SERVICES OF CALIFORNIA	WORKSHOP-MAY REVISE	700.00	DISTRICTWIDE SERVICES
180887	SCHOOL SERVICES OF CALIFORNIA	WORKSHOP	215.00	DISTRICTWIDE SERVICES
180860	SCHOOL SPECIALTY INC	laminare	317.20	Rescue School
180891	SCHOOL SPECIALTY INC	School Supplies	576.33	Lake Forest School
180849	SCHOOLMASTERS SAFETY	Safety Patrol Supplies	412.41	Lake Forest School
180839	SILKE COMMUNICATIONS INC		513.52	Transportation
180845	SWOA-SIERRA WEST OFF. ASSOC	officiating fees-athletics	750.00	Pleasant Grove Middle School
180862	UNIVERSITY OF CALIFORNIA DAVIS	Dinner with a Scientist	150.15	Marina Village School
180905	VEX ROBOTICS	PLTW supplies	44.73	Pleasant Grove Middle School
180857	WHITEBOX LEARNING	KID Wind 2.0 Subscription	395.00	Marina Village School
		TOTAL FUND	63,897.98	
		TOTAL DISTRICT	63,897.98	

FUND		AMOUNT
01	GENERAL FUND	63,897.98
	TOTAL DISTRICT	63,897.98

01 GENERAL FUND

P.O.#	VENDOR NAME	DESCRIPTION	AMOUNT	SITE NAMES
180882	ABDO	LF Library Order	2,328.12	Lake Forest School
180896	AERIES SOFTWARE	Aeries Training	1,000.00	Marina Village School
180724	ALL CHARGED UP	Replacement Parts	326.00	Lakeview
180900	AVID CENTER	Summer Institute Registration	7,155.00	Pleasant Grove Middle School
180877	BARE BOOKS	Bare Books for LF PTC	808.17	Lake Forest School
180906	BEST BUY	Classroom speakers	1,647.75	Pleasant Grove Middle School
180903	BIO CORPORATION	PLTW supplies	77.32	Pleasant Grove Middle School
180899	BULK BOOKSTORE	4th Grade Books	611.33	Lakeview
180888	BUREAU OF EDUCATION & RESEARCH	BER NGSS Conference	259.00	Marina Village School
180907	CALIFORNIA MENTAL HEALTH ADVOC	Admin Travel- Mental Health	950.00	DISTRICTWIDE SERVICES
180904	CAROLINA BIOLOGICAL SUPPLY	7th grade Science	876.89	Pleasant Grove Middle School
180847	CDW-G	Chromebook - Larry	339.95	DISTRICTWIDE SERVICES
180848	CDW-G	Call Button Kit	80.44	DISTRICTWIDE SERVICES
180876	CDW-G	Projectors: 1-JS, 2-LF, 2- RS	2,944.01	DISTRICTWIDE SERVICES
180897	CDW-G	RSP Equipment	453.64	DISTRICTWIDE SERVICES
180855	CENTER FOR AUTISM AND RELATED	IEE FBA	1,500.00	DISTRICTWIDE SERVICES
180840	CREATIVE BUS SALES INC		5,321.61	Transportation
180870	DEMCO INC	Library Supplies	966.70	DISTRICTWIDE SERVICES
180909	DISCOUNT TWO WAY RADIO CORP	Handheld Radios	3,079.91	Pleasant Grove Middle School
180863	DJ CIRCLE ENTERTAINMENT INC	Dance Rental	600.00	Pleasant Grove Middle School
180841	EL DORADO COUNTY	WORKSHOP	450.00	DISTRICTWIDE SERVICES
180853	EL DORADO COUNTY	DO-ENVELOPES	219.86	Maintenance
180859	EL DORADO COUNTY	PBIS Referral Form-NCR	254.18	Green Valley School
180854	EL DORADO MUSICAL INST REPAIR	Instrument Repairs	92.00	Pleasant Grove Middle School
180861	ENTEK CONSULTING GROUP INC		3,160.00	Maintenance
180879	FERGUSON ENTERPRISES INC		2,010.94	Operations
180844	FLINN SCIENTIFIC INC	8th Grade Science Mtls	327.28	Pleasant Grove Middle School
180852	FOLLETT SCHOOLS SOLUTIONS INC	Book order for Library	1,506.89	Jackson School
180869	FOLLETT SCHOOLS SOLUTIONS INC	Birthday Books	439.44	Lakeview
180871	FOLLETT SCHOOLS SOLUTIONS INC	Birthday Books	638.22	Lakeview
180872	FOLLETT SCHOOLS SOLUTIONS INC	Birthday Books	360.63	Lakeview
180873	FOLLETT SCHOOLS SOLUTIONS INC	Birthday Books	1,042.04	Lakeview
180874	FOLLETT SCHOOLS SOLUTIONS INC	Birthday Books	1,142.50	Lakeview
180875	FOLLETT SCHOOLS SOLUTIONS INC	Library Book Order	1,707.73	Green Valley School
180880	FOLLETT SCHOOLS SOLUTIONS INC	LF Library Order	882.54	Lake Forest School
180881	FOLLETT SCHOOLS SOLUTIONS INC	MV Awards/Honors Books	364.59	DISTRICTWIDE SERVICES
180883	FOLLETT SCHOOLS SOLUTIONS INC	PG Awards/Honors Books	250.11	DISTRICTWIDE SERVICES
180884	FOLLETT SCHOOLS SOLUTIONS INC	Spanish - Math Textbk Gr 8 -PG	100.82	DISTRICTWIDE SERVICES
180885	FOLLETT SCHOOLS SOLUTIONS INC	GV Barcodes	99.66	DISTRICTWIDE SERVICES
180032	GOOD YEAR		2,000.00	Transportation
180908	GRANITE DATA SOLUTIONS	head phones	567.89	Rescue School
180865	HARRIS CENTER FOR THE ARTS	Harris Center for the Arts	386.00	Green Valley School
180858	HCI AUDIOMETRICS	Audiometer Calibration	525.00	DISTRICTWIDE SERVICES
180889	J.W. PEPPER & SON INC	World Music BOOK/DVD	84.73	Marina Village School
180895	JOHN MCNAMEE COMPANY	PE Pacer Shirts	345.97	Marina Village School
180866	JONES SCHOOL SUPPLY CO INC	Honor Roll Bumper Stickers	231.51	Jackson School
180850	JUNIOR LIBRARY GUILD	Library Books	134.06	Lakeview
180893	JUNIOR LIBRARY GUILD	Subscription Renewal	219.94	Green Valley School
180892	KAESER & BLAIR INC.	Dog Tag Awards Library	451.00	Green Valley School
180851	MID AMERICA BOOKS	Library Books	552.62	Lakeview
180898	MONOPRICE INC	SUPPLIES	128.68	DISTRICTWIDE SERVICES

01 GENERAL FUND

P.O.#	VENDOR NAME	DESCRIPTION	AMOUNT	SITE NAMES
180846	MUSIC IN THE PARKS	Six Flags Band Festival	5,545.00	Pleasant Grove Middle School
180856	MYSTERY SCIENCE	science	499.00	Rescue School
180902	NASCO MODESTO	7th Grade Science	87.11	Pleasant Grove Middle School
180867	NCS PEARSON INC	Psych Supplies	219.90	DISTRICTWIDE SERVICES
180878	NILES BIOLOGICAL	Owl Pellets LF PTC	237.25	Lake Forest School
180842	NORTH STATE SPRING CONFERENCE	Registraton	349.00	DISTRICTWIDE SERVICES
180894	POSITIVE PROMOTIONS	Reading Counts Green Pencils	183.95	Green Valley School
180890	RISO PRODUCTS OF SACRAMENTO	Riso Supplies	299.76	Lake Forest School
180843	ROTARY CLUB OF EL DORADO HILLS	Membership	400.00	DISTRICTWIDE SERVICES
180886	SCHOOL SERVICES OF CALIFORNIA	WORKSHOP-MAY REVISE	700.00	DISTRICTWIDE SERVICES
180887	SCHOOL SERVICES OF CALIFORNIA	WORKSHOP	215.00	DISTRICTWIDE SERVICES
180860	SCHOOL SPECIALTY INC	lamine	317.20	Rescue School
180891	SCHOOL SPECIALTY INC	School Supplies	576.33	Lake Forest School
180849	SCHOOLMASTERS SAFETY	Safety Patrol Supplies	412.41	Lake Forest School
180839	SILKE COMMUNICATIONS INC		513.52	Transportation
180845	SWOA-SIERRA WEST OFF. ASSOC	officiating fees-athletics	750.00	Pleasant Grove Middle School
180862	UNIVERSITY OF CALIFORNIA DAVIS	Dinner with a Scientist	150.15	Marina Village School
180905	VEX ROBOTICS	PLTW supplies	44.73	Pleasant Grove Middle School
180857	WHITEBOX LEARNING	KID Wind 2.0 Subscription	395.00	Marina Village School
		TOTAL FUND	63,897.98	
		TOTAL DISTRICT	63,897.98	

FUND		AMOUNT
01	GENERAL FUND	63,897.98
	TOTAL DISTRICT	63,897.98

ITEM #: 16A
DATE: April 10, 2018

RESCUE UNION SCHOOL DISTRICT

AGENDA ITEM: Classified Personnel

BACKGROUND:

Periodically changes in classified staffing occur due to hiring, resignations or requests for leaves of absence. The Board must formally approve these requests.

STATUS:

The following classified personnel changes are listed on the agenda:

Name	Personnel Action	Position FTE	Position	School/Dept.	Effective Date
Curtin, Ambra	Employment	.3125	Food Service Worker	Marina Village	3/15/18
Kesner, Stacey	Employment	.375	IA Paraeducator	Rescue	3/12/18
Shue, Susan	Employment	.3125	Short Term Student Secretary	Marina Village	3/12/18
Popovich, Nichole	Employment	.75	Short Term Itinerant Independence Facilitator	Marina Village	3/13/18
Phillips, Sarah	Promotion	1.0	School Secretary	Green Valley	3/2/18
Higuchi, Kore	Resignation	.3750	Custodian	Jackson	3/21/18

FISCAL IMPACT:

Fiscal impact will be reflected in the 2017-18 budget years.

BOARD GOAL:

Board Focus Goal IV – STAFF NEEDS:

Attract and retain diverse, knowledgeable, dedicated employees who are skilled and supported in their commitment to providing quality education for our students.

RECOMMENDATION:

The Superintendent recommends the Board approve the above personnel actions.

RESCUE UNION SCHOOL DISTRICT

**AGENDA ITEM: MARINA VILLAGE MIDDLE SCHOOL
TWO-STORY CLASSROOM PROJECT**

Change Order(s) # 10-16
Carter Kelly, Inc.

BACKGROUND:

In January of 2017, the Governing Board of the Rescue Union School District established an RFQ and RFP from qualified providers of Lease-Leaseback (“L/LB”) construction services for the *Construction of a Two-Story Classroom Building, Sitework and Modernization Project at Marina Village Middle School*. The District received qualification packets from five construction services firms, all of whom were prequalified to submit a fee based proposal on the Project. Subsequently, three of the construction services firms submitted a fee based proposal on the project by which contracts will be awarded by the Board under the provisions of Education Code 17406 *et seq.*

Through the facility planning process, the District identified modernization projects throughout the District including the construction of a two-story classroom building at Marina Village Middle School. The estimated construction cost of the Marina Village Two-Story Classroom Building Project is approximately \$6.5 million.

- **Marina Village Middle School:**

The District expand the permanent capacity on the campus of Marina Village Middle School, a District-owned site located at 1901 Francisco Drive, El Dorado Hills, California 95762 by constructing a new two-story classroom building and completing other site work, and modernization work related to the Project.

On March 14, 2017, the Governing Board passed Resolution #17-07 delegating to the Superintendent, or their designee, the authority to enter into the Lease Leaseback Contract for Construction Services, the Site Lease, and Sublease Agreement and other acts relating to the Marina Village Two-Story Classroom Project with Carter-Kelly Inc. who provided the best value in the competitive procurement process as directed under the provisions of Education Code 17406 *et seq.*

The District received approval of the plans from the Division of State Architects (DSA) on March 8, 2017 allowing Carter-Kelly Inc. to determine its Guaranteed Maximum Price (GMP) on the Marina Village Two-Story Classroom Project once bids were submitted by qualified sub-contractors. The total construction cost for the project is \$6,486,004. In addition, the LLB Construction Services Contract with Carter-Kelly Inc. at 11.5% is \$745,890, thereby generating a Guaranteed Maximum Price (GMP) of \$7,231,894. This contract was approved by the board at the June 13, 2017 meeting.

At the December 12, 2017 board meeting, Change Orders #1 – 4 were approved for a net change to the contract of \$28,146. When added to the original contract amount, the revised contract was \$7,260,040.00.

At the January 23, 2018 board meeting, Change Orders #5 – 9 were approved for a net change to the contract of \$250,036.00. When added to the revised contract amount, the updated contract was \$7,510,076.00.

STATUS:

Carter Kelly, Inc. has begun the construction of the two-story classroom project and site work at Marina Village Middle School and has submitted Change Orders #10-16 for a net increase of \$18,167.00 to the contract.

Change Order # 10 – Credit for Fixtures Bathroom – (\$432.00)

Change Order # 11 – Light Fixture - \$2,749.00

Change Order # 12 – SPED Door – \$1,634.00

Change Order # 13 – Janitor Closet Changes – \$5,066.00

Change Order # 14 – Science Change - \$14,884.00

Change Order # 15 – Credit for Fire Alarm System Change – (\$5,734.00)

Change Order # 16 – Door Change Net Zero - \$0.00

FISCAL IMPACT:

The total cost of Change Orders #10-16 is \$18,167.00. When added to the current contract amount, the new contract will be \$7,528,243.00

LONG-RANGE GOALS:

Board Focus Goal II – FISCAL ACCOUNTABILITY:

Keep the district fiscally solvent through prudent LCAP aligned budget processes in order to meet the needs of our students.

Board Focus Goal V - FACILITY / HOUSING:

Build, improve and maintain school facilities to meet current and future education needs while integrating the most effective and efficient use of resources.

Local Control Accountability Plan

GOAL 6:

The District will create and maintain facilities and grounds that are safe, clean and conducive to the learning process.

RECOMMENDATION:

Board of Trustees approve Change Orders #10-16 for \$18,167.00 to the contract with Carter Kelly, Inc., General Contractor for the Marina Village two-story classroom building project.

Carter-Kelly, Inc.

CHANGE ORDER

No. 00010

P.O. Box 1477
Placerville, CA 95667

Phone: 530-621-0950
Fax: 530-621-2344

TITLE: Owner CO 10 deductive PR 10
PROJECT: Marina Village Portable Replacement

DATE: 01/05/2018

JOB:

TO: Attn: Phil Jones
Rescue Union School District
2390 Bass Lake Road
Rescue, CA 95672

CONTRACT NO: 26

Phone: 530-672-4302 Fax: 530-677-5182

Item	Description	Stock#	Quantity	Units	Unit Price	Tax Rate	Tax Amount	Net Amount	
00001	Deductive CO per PR 10		1.000		(\$432.00)	0.00%	\$0.00	(\$432.00)	
								Unit Cost:	(\$432.00)
								Unit Tax:	\$0.00
								Total:	(\$432.00)

The Original Contract Sum was	\$7,231,894.00
Net Change by Previously Authorized Requests and Changes	\$278,182.00
The Contract Sum Prior to This Change Order was	\$7,510,076.00
The Contract Sum Will be Decreased	\$432.00
The New Contract Sum Including This Change Order	\$7,509,644.00
The Contract Time Will Not be Changed	
The Date of Substantial Completion as of this Change Order Therefore is	

ACCEPTED:

Rescue Union School District

Carter-Kelly, Inc.

CALIFORNIA DESIGN WEST

By: _____
Phil Jones

By: Carl Dingle
Carl Dingle

By: Mitch McAllister
Mitch McAllister

Date: 01/05/2018

Date: 01/05/2018

Date: 01/05/2018

CONTRACTOR PROPOSAL – COST BREAKDOWN

Anne Perkins
 Project: Marina Village
 Date: Dec. 14, 2017



DESCRIPTION OF WORK: PR 10

I. CKI LABOR	RATE	HOURLY(S)	\$ AMOUNT
CLASSIFICATION			
Superintendent -	85		\$0
Carpenters / Cement Masons	75		\$0
Laborer	70		\$0
TOTAL DIRECT LABOR			\$0
OVERHEAD PROFIT/FEE@		15%	\$0
TOTAL FOR LABOR			\$0

II. CKI MATERIAL	QUANTITY	UNIT PRICE	\$ AMOUNT
TOTAL DIRECT MATERIAL			\$0
OVERHEAD PROFIT/FEE@		15%	\$0
TOTAL FOR MATERIAL			\$0

III. CKI EQUIPMENT	RATE	Months	\$ AMOUNT
TOTAL DIRECT EQUIPMENT			\$0
OVERHEAD PROFIT/FEE@		15%	\$0
TOTAL FOR EQUIPMENT			\$0

IV. SUBCONTRACTORS		\$ AMOUNT
CAPCO (Credit)		-\$411
TOTAL DIRECT SUBCONTRACTOR		-\$411
OVERHEAD PROFIT/FEE@		5%
TOTAL FOR SUBCONTRACTOR		-\$432

COST PROPOSAL TOTAL **-\$432**

COMPANY: Carter-Kelly, Inc

SIGNATURE:

PRINT NAME: Carl Dingle

TITLE: Project Manager



**CAPITOL ARCHITECTURAL
PRODUCTS CO.**

QUOTE

8310 Belvedere Avenue • Sacramento, CA 95826
(916) 387-0777 • FAX (916) 387-1276

COMPANY NAME: Carter Kelly, Inc.

DATE: December 7, 2017

ATTN: Carl D.

SALESPERSON	JOB NAME	SHIP VIA	DELIVERY DATE	PAYMENT TERMS
James N Brown	Marina Middle School RR Accessories			Net 30 Days

QUANTITY	DESCRIPTION	UNIT PRICE	T	AMOUNT
6	Toilet Tissue Dispenser B-686			
3	Grab Bar 1 1/2" B-6806-36"			
3	Grab Bar 1 1/2" B-6806-42"			
5	Mirror 24" x 36" B-165			
1	Napkin /Tampon Vendor B-2706 (C/.25/.50)			
1	Paper Towel Dispenser B-2620			
5	Soap Dish B-40			
3	Multi-Roll Toilet Tissue Dispenser B-4388			
5	Sanitary Napkin Disposal			
2	Aircraft Automatic Hand Dryer B-750 (115V or 230V?)			
Quote is valid for 30 days.				

TAXABLE SUBTOTAL	3,997.23
TAX RATE	8.25%
SALES TAX	329.77
NON-TAXABLE SUBTOTAL	
SHIPPING & HANDLING	
TOTAL	\$ 4,327.00

Quote accepted by: _____

james.brown@capcosac.com

THANK YOU FOR YOUR BUSINESS!



**CAPITOL ARCHITECTURAL
PRODUCTS CO.**

QUOTE

8310 Belvedere Avenue • Sacramento, CA 95826
(916) 387-0777 • FAX (916) 387-1276

COMPANY NAME: Carter Kelly, Inc.

DATE: December 14, 2017

ATTN: Carl D.

SALESPERSON	JOB NAME	SHIP VIA	DELIVERY DATE	PAYMENT TERMS
James N Brown	Marina Middle School RR Accessories			Net 30 Days

QUANTITY	DESCRIPTION	UNIT PRICE	T	AMOUNT
6	Toilet Tissue Dispenser B-2888			
3	Grab Bar 1 1/2" B-6806-36"			
3	Grab Bar 1 1/2" B-6806-42"			
5	Mirror 24" x 36" B-165			
1	Napkin /Tampon Vendor B-2706 (C/.25/.50)			
3	Multi-Roll Toilet Tissue Dispenser B-3888			
5	Sanitary Napkin Disposal B-270			
2	Aircraft Automatic Hand Dryer B-750 (115V or 230V?)			
Quote is valid for 30 days.				

TAXABLE SUBTOTAL	3,617.55
TAX RATE	8.25%
SALES TAX	298.45
NON-TAXABLE SUBTOTAL	
SHIPPING & HANDLING	
TOTAL	\$ 3,916.00

Quote accepted by: _____

james.brown@capcosac.com

THANK YOU FOR YOUR BUSINESS!

Carter-Kelly, Inc.

CHANGE ORDER

No. 00011

P.O. Box 1477
Placerville, CA 95667

Phone: 530-621-0950
Fax: 530-621-2344

TITLE: Owners CO 11 PR 11 **DATE:** 02/14/2018

PROJECT: Marina Village Portable Replacement **JOB:**

TO: Attn: Phil Jones **CONTRACT NO:** 26

Rescue Union School District
2390 Bass Lake Road
Rescue, CA 95672

Phone: 530-672-4302 Fax: 530-677-5182

Item	Description	Stock#	Quantity	Units	Unit Price	Tax Rate	Tax Amount	Net Amount
00001	Added scope per proposal request 11		1.000		\$2,749.00	0.00%	\$0.00	\$2,749.00

Unit Cost: \$2,749.00
Unit Tax: \$0.00
Total: \$2,749.00

The Original Contract Sum was	\$7,231,894.00
Net Change by Previously Authorized Requests and Changes	\$277,750.00
The Contract Sum Prior to This Change Order was	\$7,509,644.00
The Contract Sum Will be Increased	\$2,749.00
The New Contract Sum Including This Change Order	\$7,512,393.00
The Contract Time Will Not be Changed	
The Date of Substantial Completion as of this Change Order Therefore is	

ACCEPTED:

Rescue Union School District

Carter-Kelly, Inc.

CALIFORNIA DESIGN WEST

By: 
Phil Jones

By: Carl Dingle
Carl Dingle

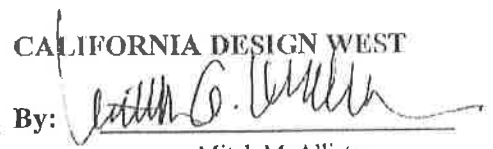
By: 
Mitch McAllister

Date: 02/14/2018

Date: 02/14/2018

Date: 02/14/2018



PROPOSAL REQUEST

CALIFORNIA DESIGN WEST ARCHITECTS INC.

2100 19TH STREET | SACRAMENTO CA 95818 | 916.446.2466 | WWW.CA-DW.COM

PROJECT:

Marina Village MS – Portable Classroom Replacement
DSA App # 02-115519; DSA File # 9-45

PROPOSAL REQUEST NO.: 11

DATE OF ISSUANCE: 12/13/17

OWNER:

Rescue Union School District
2390 Bass Lake Road
Rescue, CA 95370

CONTRACTOR:

Carter-Kelly, Inc.
P.O. Box 1477
Placerville, CA 95667

PLEASE SUBMIT AN ITEMIZED QUOTATION FOR CHANGES IN THE CONTRACT SUM AND/OR TIME INCIDENTAL TO PROPOSED MODIFICATIONS TO THE CONTRACT DOCUMENTS DESCRIBED HEREIN. THIS IS NOT A CHANGE ORDER NOR A DIRECTION TO PROCEED WITH THE WORK DESCRIBED HEREIN.

ADDITIONAL LIGHT FIXTURE – TYPE J:

As noted in RFI # 70, Contractor to provide pricing to add one (1) additional Light Fixture Type J adjacent to Fire Riser Room D113 on the SW corner of the new Classroom Building.

REFERENCE:

RFI # 70

REQUESTED BY:

Signature

Garret Feasel

Name

Carter-Kelly, Inc.

CHANGE ORDER

No. 00012

P.O. Box 1477
Placerville, CA 95667

Phone: 530-621-0950
Fax: 530-621-2344

TITLE: Owner CO 12 PR 13 **DATE:** 02/14/2018

PROJECT: Marina Village Portable Replacement **JOB:**

TO: Attn: Phil Jones **CONTRACT NO:** 26
Rescue Union School District
2390 Bass Lake Road
Rescue, CA 95672

Phone: 530-672-4302 Fax: 530-677-5182

Item	Description	Stock#	Quantity	Units	Unit Price	Tax Rate	Tax Amount	Net Amount
00001	Scope change per proposal request 13		1.000		\$1,634.00	0.00%	\$0.00	\$1,634.00

Unit Cost: \$1,634.00
Unit Tax: \$0.00
Total: \$1,634.00

The Original Contract Sum was	\$7,231,894.00
Net Change by Previously Authorized Requests and Changes	\$280,499.00
The Contract Sum Prior to This Change Order was	\$7,512,393.00
The Contract Sum Will be Increased	\$1,634.00
The New Contract Sum Including This Change Order	\$7,514,027.00
The Contract Time Will Not be Changed	
The Date of Substantial Completion as of this Change Order Therefore is	

ACCEPTED:

Rescue Union School District

Carter-Kelly, Inc.

CALIFORNIA DESIGN WEST

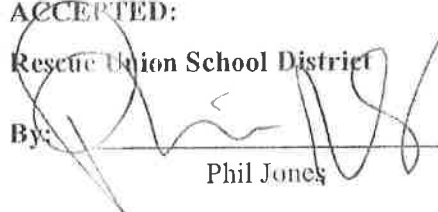
By: 
Phil Jones

By: Carl Dingle
Carl Dingle

By: 
Mitch McAllister

Date: 02/14/2018

Date: 02/14/2018

Date: 02/14/2018



PROPOSAL REQUEST

CALIFORNIA DESIGN WEST ARCHITECTS INC.

2100 19TH STREET | SACRAMENTO CA 95818 | 916.446.2466 | WWW.CA-DW.COM

PROJECT:
Marina Village MS – Portable Classroom Replacement
DSA App # 02-115519; DSA File # 9-45

PROPOSAL REQUEST NO.: 13
DATE OF ISSUANCE: 01/17/18

OWNER:
Rescue Union School District
2390 Bass Lake Road
Rescue, CA 95370

CONTRACTOR:
Carter-Kelly, Inc.
P.O. Box 1477
Placerville, CA 95667

PLEASE SUBMIT AN ITEMIZED QUOTATION FOR CHANGES IN THE CONTRACT SUM AND/OR TIME INCIDENTAL TO PROPOSED MODIFICATIONS TO THE CONTRACT DOCUMENTS DESCRIBED HEREIN. THIS IS NOT A CHANGE ORDER NOR A DIRECTION TO PROCEED WITH THE WORK DESCRIBED HEREIN.

DOOR BETWEEN D101 AND D102:

Contractor to provide credit to delete tackwall, gyp board, insulation, and additional casework added in PR # 6, and to provide pricing for material and installation of a new HM Framed, Plastic Laminated Faced Door between rooms D101 and D102, as shown on the attached drawings PR13-A101, and PR13-A291. Hardware to be Group #8.2, as listed below. All notes from reviewed Submittal # 26 apply to this hardware group:

Group 8.2: Interior – Classroom to Classroom:

EACH DOOR TO HAVE:

3	EA	HEAVY DUTY HINGE	5BB1HW 4-1/2 x 4-1/2 NRP	652	IV
1	EA	LOCK	ND66TD RHO 50-215	626	SC
2	EA	CYLINDER CORE	* 20-740-XP EVEREST-PRIMUS	626	SC
* COORDINATE CYLINDER TYPES WITH PHIL JONES PRIOR TO ORDERING					
1	EA	FLOOR STOP & HOLDER	FS43	US26D	IV
3	EA	SILENCER	SR64	GRY	IV

ATTACHMENTS:

PR13-A101, and PR13-A291

REQUESTED BY:

Signature 

Garret Feasel
Name

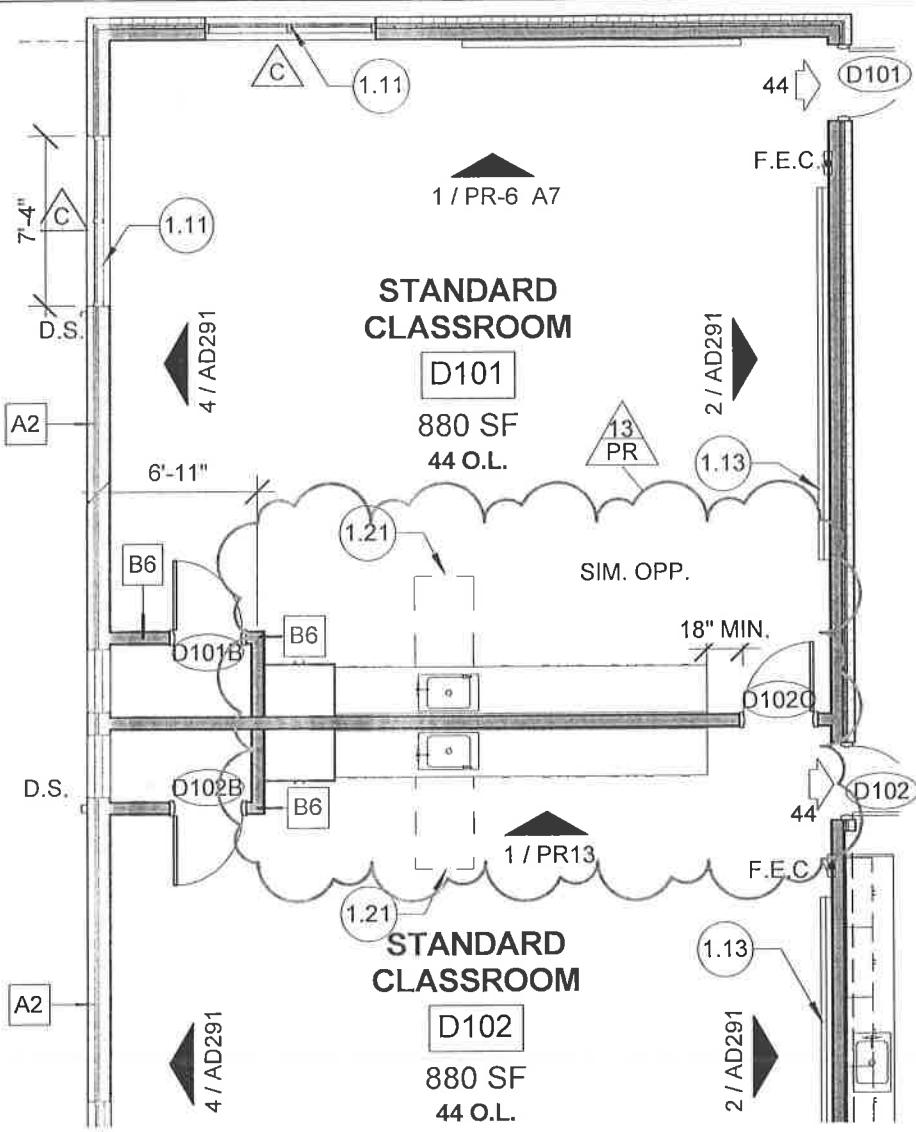

1 **FIRST FLOOR PLAN**
 1/8" = 1'-0"

DOOR SCHEDULE 1ST FLR PR13

1. DOOR #	DOORS				5. Glass	6. FIRE RATING	FRAME		DETAILS			10. HARDWARE	11. KEYNOTES	1. DOOR #
	2. TYPE	WIDTH	HEIGHT	3. THICKNESS			4. FINISH	7. TYPE	8. FINISH	HEAD	JAMB			
D102C		3'-0"	7'-0"	1 3/4"	SCL	-	A	HM	D3/571	D2/571		8.2	3	D102C



CALIFORNIA DESIGN WEST ARCHITECTS INC.
 2100 19TH STREET, SACRAMENTO, CA 95818
 PHONE: (916) 446-2466 FAX: (916) 446-5118

**PORTABLE CLASSROOM
 REPLACEMENT**
 RESCUE UNION SCHOOL DISTRICT
 DSA FILE NO: 9-45
 DSA APPL. NO: 02-115519
 OPSC APPL. NO:

UNIT:	SHT. OF SHTS.
JOB NO.	DATE: JAN. 12, 2018
DRAWN BY GLF	DRAWING NO: PR13 A101
CHECKED	

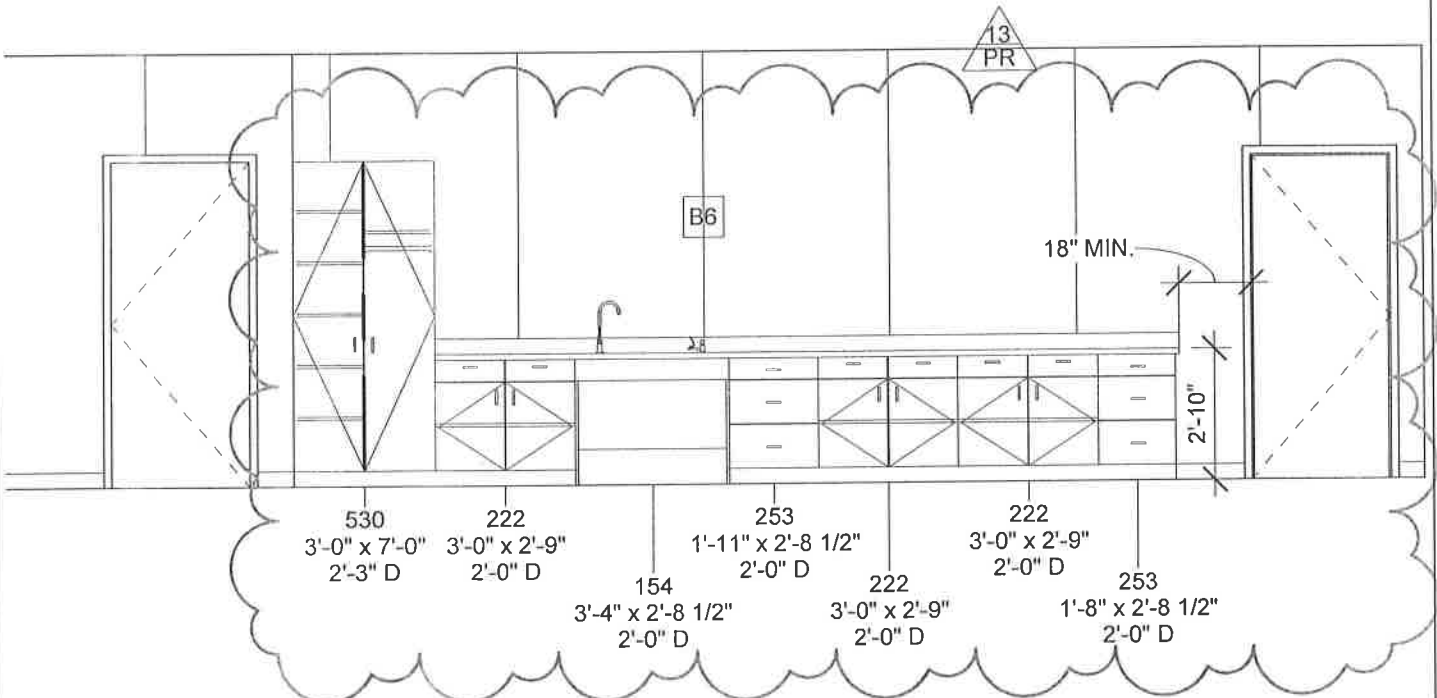

1 TYP. CLASSROOM D101 & D102

1

1/4" = 1'-0"



CALIFORNIA DESIGN WEST ARCHITECTS INC.
 2100 19TH STREET, SACRAMENTO, CA 95818
 PHONE: (916) 446-2466 FAX: (916) 446-5118

PORTABLE CLASSROOM REPLACEMENT

RESCUE UNION SCHOOL DISTRICT

DSA FILE NO: 9-45

DSA APPL. NO: 02-115519

OPSC APPL. NO:

UNIT: SHT. OF SHTS.

JOB NO. DATE:
 JAN. 12, 2018

DRAWN BY DRAWING NO:

Author PR13
 CHECKED A291
 Checker

Carter-Kelly, Inc.

CHANGE ORDER

No. 00013

P.O. Box 1477
Placerville, CA 95667

Phone: 530-621-0950
Fax: 530-621-2344

TITLE: Owner CO 13 PR4

DATE: 02/14/2018

PROJECT: Marina Village Portable Replacement

JOB:

TO: Attn: Phil Jones
Rescue Union School District
2390 Bass Lake Road
Rescue, CA 95672

CONTRACT NO: 26

Phone: 530-672-4302 Fax: 530-677-5182

Item	Description	Stock#	Quantity	Units	Unit Price	Tax Rate	Tax Amount	Net Amount
00001	Scope change per PR 4		1.000		\$5,066.00	0.00%	\$0.00	\$5,066.00

Unit Cost: \$5,066.00
Unit Tax: \$0.00
Total: \$5,066.00

The Original Contract Sum was	\$7,231,894.00
Net Change by Previously Authorized Requests and Changes	\$282,133.00
The Contract Sum Prior to This Change Order was	\$7,514,027.00
The Contract Sum Will be Increased	\$5,066.00
The New Contract Sum Including This Change Order	\$7,519,093.00
The Contract Time Will Not be Changed	
The Date of Substantial Completion as of this Change Order Therefore is	

ACCEPTED:

Rescue Union School District

Carter-Kelly, Inc.

CALIFORNIA DESIGN WEST

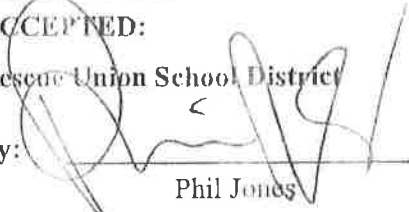
By: 
Phil Jones

By: 
Carl Dingle

By: 
Mitch McAllister

Date: 02/14/2018

Date: 02/14/2018

Date: 02/14/2018

CONTRACTOR PROPOSAL – COST BREAKDOWN



California Design West
Marina Village
Date: 2-9-18

DESCRIPTION OF WORK: Proposal Request 4

I. CKI LABOR	RATE	HOUR(S)	\$ AMOUNT
CLASSIFICATION			
Superintendent -	93	8	\$744
Carpenters / Cement Masons	91		\$0
Laborer	85		\$0

TOTAL DIRECT LABOR			\$744
OVERHEAD PROFIT/FEE@	11.5%		\$86
TOTAL FOR LABOR			\$830

II. CKI Labor	Units

III. CKI EQUIPMENT	RATE	Months	\$ AMOUNT

IV. SUBCONTRACTORS	\$ AMOUNT
Allens Cabinets	-\$1,505
BT Macini	\$145
Greco Mechanical	\$1,575
James Harris Painting	\$1,271
Universal plastic	\$450
WWF Contractors	\$2,819
Myers and sons Drywall	-\$720

TOTAL DIRECT SUBCONTRACTOR		\$4,035
OVERHEAD PROFIT/FEE@	11.5%	\$202
TOTAL FOR SUBCONTRACTOR		\$4,237

COST PROPOSAL TOTAL \$5,066

COMPANY: Carter-Kelly, Inc SIGNATURE:
PRINT NAME: Carl Dingle TITLE: Project Manager

JAMES L. HARRIS'
PAINTING & DECORATING, INC.
License No. 745726

P.O. Box 3183
Auburn, CA 95604-3183

(530) 888-0580

(877) 245-7703 FAX

DATE: January 25, 2018

TO: Carl Dingle Carter Kelly Inc.

PROJECT: Marina Village

FROM: Chris Harris cjh@jllhpainting.com Cell – (530) 308-2123

REQUEST FOR QUOTATION

(Reference e-mail request of 1/23/18)

Qualifications -

Union labor workforce – Normal Working hours

PR #4 -

1. Add epoxy coatings of walls in room D-205

- Access to working surfaces
- Minor preparation of substrates
- Protection of adjacent surfaces
- Application of waterborne epoxy coatings (Color – TBD)

Labor -	12 hours @ \$65.00	\$780
Mark-up -	\$780 x 15% = \$117	
Total Labor -		\$897
Materials -	5 gallons @ \$65.00	\$325
Mark-up -	\$325 x 15% = \$49	
Total Materials -		\$374
Total -		\$1,271.00

Total Quote - \$1,271.00

STANDARD EXCLUSIONS -

- SURFACES READY FOR PAINT COATINGS
- HAZARDOUS MATERIALS MANAGEMENT (ASBESTOS / MOLD / LEAD BASED PAINT)
- ALL DAMAGE AND/OR COATINGS REPAIR (WITHOUT ADDITIONAL COMPENSATION)

SSPC MEMBER

STATE OF CALIFORNIA CERTIFIED SMALL BUSINESS

UNION SIGNATORY

MEMO TO: Carter Kelly JOB #1725
ATTN: Carl Dingle
MEMO FROM: Laine West, Jeff Fry
DATE: February 12, 2018
PROJECT: Marina Village MS
RE: PR #04-D205 Teacher Work Room Changes CREDIT to omit sink & faucet at casework

LABOR

1 hr. @ 120.87/hr.		120.87
	Total labor credit	-120.87

MATERIAL

(1) Sink @ 255.00/ea.		255.00
(1) Faucet @ 185.00/ea.		185.00
Misc. hardware, angle stops, traps, tail pieces @ 50.00		50.00
	Subtotal material	490.00
	Sales tax @ 7.75%	37.98
	Material total credit	-527.98
	Labor & material total CREDIT	-648.85

Please note that rough-in plumbing has already been completed, so there will not be a credit issued for this work



9823 Old Winery Place, Ste. 20
Sacramento, CA 95827
Office: 916.853.0514
Fax: 916.853.0515

CSLB # 410113

www.wwfcontractors.com



CHANGE ORDER (CREDIT)

Project Name	Marina Village Middle School	Change Number	01809
Requested By	Carl Dingle	Date of Request	02-10-18
Presented To	Carter Kelly Inc.		

Change Name	PR # 4
-------------	--------

Description of Change: Deduct for deletion of tackable wall panels in janitor work room

Application includes:

Application excludes:

Effect on Schedule (including Estimated Completion Date for this change):

Credit: [\$720.00]

Myers & Sons Drywall Inc.

Signature:  _____
Title: President _____ Date: 02-10-18 _____

Owner/ Corporate Officer/Project Manager

Approved Signature: _____
 Rejected Title: _____ Date: _____



ALLEN'S

CABINET & FIXTURE, INC.

January 23 2018

Carter-Kelly, Inc.

P.O. Box 1477 Placerville, CA

95667

ATTN: Carl Dingle

RE: Marina Village

Carl,

Please find below our price below to omit room D205.

Omit room D205

Deduct (-1505.00)

TOTAL CHANGE ORDER REQUIRED: \$(-1505.00)

*Please provide change order to proceed

Sincerely

Keith Henderson

Project Manager

140 FLOCCINI CIRCLE LINCOLN, CA 95648 PHONE # (916) 434-3800 FAX # (916) 434-3804



License #931227
 4001 Uniontown Rd.
 Lotus, CA 95651
 Ph: (530) 919-2104
 Fax: (530) 621-0381
 john@grecomechanical.com
 www.grecomechanical.com

CHANGE ORDER REQUEST

To: Carter Kelly, Inc.
 P.O. Box 1477
 171 Middletown Road
 Placerville, CA 95667

Order No. 9
 Date: 1/25/2017
 Job No: 190

Attn: Carl Dingle

Project: Marina Village MS Portable Replacement 2017

Ref: PR04

Quantity	Item	Unit Cost	Total
1	Installation of (1) ceiling exhaust fan system and Controls interlock		
	Material & Labor	\$1,431.62	\$1,431.62
		Sub total:	\$1,431.62
		10% O/P	\$143.16
		Total	\$1,574.78

UNIVERSAL PLASTICS, INC

PROPOSAL AND CONTRACT

1020 Winding Creek Rd, Suite 130, Roseville, CA 95678

Phone (916)787-0541 & Fax (916)787-0692

California License #390876 & Nevada License #0006651

FRP Panels/Slatwall/ Laminated and Solid Surface Counter Tops/Marlite

BID LIMIT - NONE

Date: January 24, 2018

Quote #: ST 20082-0

Name: Carter Kelly
Attention:
Job Address: Marina Village Middle School
1901 Francisco Dr.
El Dorado Hills, CA 95762

The undersigned agrees to furnish and provide all necessary Labor and Material to perform and complete in a good workman- like manner the following:

(UNION - YES) (BONDABLE - YES) - (WOMAN OWNED - NO) (MINORITY OWNED -NO)
(SMALL BUSINESS CERTIFIED - YES - # 32633)

No Spec.

Furnish & Install FRP at Mop Sink in D205 Janitors Office ----- \$ 450.00

Tax Included

Total: \$ 450.00

Any alterations or deviation from the above, involving extra cost of material or labor, will become an extra charge over the sum mentioned above. In the event that it becomes necessary to institute suit or to employ an attorney to collect any payment or payments due the undersigned for labor or materials fees shall be in an amount equal to one-third of the amount for which recovery is paid. Terms of payment shall be as follows: Net 30 Days.

This proposal is void if not accepted within 30 Days.

Respectfully submitted,

BY _____
Steve Tullgren President

ACCEPTANCE

You are hereby authorized to furnish all materials and labor required to complete the work mentioned in the above proposal for which we agree to pay the amount mentioned in said proposal and in accordance with the terms

ACCEPTED AND AUTHORIZED BY

Date: _____

Signed: _____

Printed Name: _____

DIR #1000001171



B.T. Mancini Co., Inc.

8571 23rd Ave.
Sacramento CA 95827
916-381-3660 fax: 916 381-6645
DIR #1000002989

Date: 1/22/18

Attention: Carl Dingle
Company: Carter-Kelly

Project: Marina Village MS
Portable Classroom Replacement Project
Proposal Request #4 Teacher Workroom Change
BT Mancini CO #B

The following is our added costs as per Proposal Request #4 dated 1/19/18, to change the flooring in the Teacher Workroom change to Janitors Office:

- | | |
|---|--------------------|
| 1. Delete Tandus Carpet in Teachers Workroom #D205: | <\$1,919.00> |
| 2. Add Forbo MCT in New Janitors Office #D205: | <u>+\$2,064.00</u> |
| ** Net Add CO #B: | +\$145.00 |

** BT Mancini will require written acceptance of these costs before ordering of material and scheduling of labor.

Scott Sievers

Respectfully Submitted,
Scott Sievers

QUOTATION ACCEPTANCE:

This quotation, unless otherwise noted, will remain in effect for 30 days from the above date. Upon acceptance by the Buyer and credit approval by the B.T. Mancini Co., Inc. this instrument shall constitute a binding contract. In the event the Buyer elects to issue his own purchase order or contract based on this quotation, the conditions contained herein shall be deemed to be incorporated in said purchase order or contract. This proposal expressly limits acceptance to terms of The General Conditions of Sale contained herein. No terms additional or different from The General Conditions will be accepted, including, but not limited to, any terms which establish a "condition precedent" to the Buyer making payment to the Seller other than any "condition precedent" already contained in this proposal. **The undersigned hereby accepts this proposal and states that he has read The General Conditions of Sale on the reverse side.**

Accepted: _____

Print Name: _____

Company: _____

Date: _____

California Contractors License #229210 SPECIALTY CONTRACTORS Nevada Contractors License #0010497

MEMO TO: Carter Kelly
ATTN: Carl Dingle
MEMO FROM: Laine West
DATE: January 23, 2018
PROJECT: Marina Village MS
RE: PR #04-D205 Teacher Work Room Changes

JOB #1725

LABOR

18 hrs. @ 120.87/hr.		2175.66
	Total labor	2175.66

MATERIAL

(1) SS-1 Mop sink @ 431.35/ea.	431.35	
(1) SS-1 Faucet @ 158.41/ea.	158.41	
(1) 4 x 3 combo @ 19.27/ea.	19.27	
(2) 3" 90 @ 13.60/ea.	27.20	
(1) 3" San tee @ 14.20/ea.	14.20	
(1) 3" P-trap @ 34.11/ea.	34.11	
(1) 3 x 2 reducer @ 7.90/ea.	7.90	
(2) 2" 90 @ 11.03/ea.	22.06	
(1) 2" San tee @ 12.56/ea.	12.56	
(10) 3" No hub @ 4.89/ea.	48.90	
(25) 2" No hub @ 3.71/ea.	92.75	
(2) 4" Bands @ 8.89/ea.	17.78	
(10) 3" Bands @ 7.92/ea.	79.20	
(1) 2" Bands @ 7.14/ea.	7.14	
Misc. 3/4 copper pipe & fittings @ 40.00	40.00	
Misc. strapping material @ 30.00	30.00	
	Subtotal material	1042.83
	Sales tax @ 7.75%	80.82
	15% Profit & Overhead	168.55
	Material total	1292.20
	Labor & material total	3467.86



9823 Old Winery Place, Ste. 20
Sacramento, CA 95827
Office: 916.853.0514
Fax: 916.853.0515

CSLB # 418113

www.wwfcontractors.com

Carter-Kelly, Inc.

CHANGE ORDER

No. 00014

P.O. Box 1477
Placerville, CA 95667

Phone: 530-621-0950
Fax: 530-621-2344

TITLE: Owener CO 14 PR 1R2

DATE: 02/14/2018

PROJECT: Marina Village Portable Replacement

JOB:

TO: Attn: Phil Jones
Rescue Union School District
2390 Bass Lake Road
Rescue, CA 95672

CONTRACT NO: 26

Phone: 530-672-4302 Fax: 530-677-5182

Item	Description	Stock#	Quantity	Units	Unit Price	Tax Rate	Tax Amount	Net Amount
00001	Change of scope per PR 1R2		1.000		\$14,884.00	0.00%	\$0.00	\$14,884.00
Unit Cost:								\$14,884.00
Unit Tax:								\$0.00
Total:								\$14,884.00

The Original Contract Sum was	\$7,231,894.00
Net Change by Previously Authorized Requests and Changes	\$287,199.00
The Contract Sum Prior to This Change Order was	\$7,519,093.00
The Contract Sum Will be Increased	\$14,884.00
The New Contract Sum Including This Change Order	\$7,533,977.00
The Contract Time Will Not be Changed	
The Date of Substantial Completion as of this Change Order Therefore is	

ACCEPTED:

Rescue Union School District

Carter-Kelly, Inc.

CALIFORNIA DESIGN WEST

By: _____
Phil Jones

By: _____
Carl Dingle

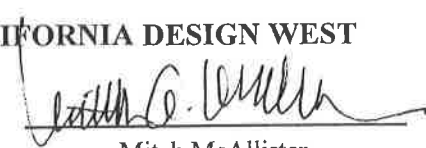
By: 
Mitch McAllister

Date: 02/14/2018

Date: 02/14/2018

Date: 02/14/2018

CONTRACTOR PROPOSAL – COST BREAKDOWN

California Design West
Marina Village
Date: Dec. 5, 2017



DESCRIPTION OF WORK: PR 1

I. CKI LABOR	RATE	HOUR(S)	\$ AMOUNT
CLASSIFICATION			
Superintendent -	93	4	\$372
Carpenters - install cabinets and refrigerator	91	16	\$1,456
Laborer	85		\$0
TOTAL DIRECT LABOR			\$1,828
OVERHEAD PROFIT/FEE@		11.5%	\$210
TOTAL FOR LABOR			\$2,038

II. CKI MATERIAL	QUANTITY	UNIT PRICE	\$ AMOUNT
Eagle 4510 flammable storage cabinet			\$1,012
Eagle CPA 70 chemical storage cabinet			\$1,085
Shipping			\$445
Kenmore refrigerator 4641173			\$826
Shipping			\$150
TOTAL DIRECT MATERIAL			\$3,518
OVERHEAD PROFIT/FEE@		11.5%	\$405
TOTAL FOR MATERIAL			\$3,923

III. SUBCONTRACTORS CREDIT	RATE	Months	\$ AMOUNT
Allen's Cabinets			-\$5,385
TOTAL DIRECT EQUIPMENT			-\$5,385
OVERHEAD PROFIT/FEE@		5.0%	(\$269)
TOTAL FOR EQUIPMENT			-\$5,654

IV. SUBCONTRACTORS	\$ AMOUNT		
Greco Mechanical	\$5,565		
WWF Contractors	\$2,453		
Alessandro Electric	\$5,056		
TOTAL DIRECT SUBCONTRACTOR		\$13,074	
OVERHEAD PROFIT/FEE@		11.5%	\$1,504
TOTAL FOR SUBCONTRACTOR		\$14,578	

COST PROPOSAL TOTAL	\$14,884
----------------------------	-----------------

COMPANY: Carter-Kelly, Inc

SIGNATURE:

PRINT NAME: Carl Dingle

TITLE: Project Manager

MEMO TO: Carter Kelly
ATTN: Carl Dingle
MEMO FROM: Laine West
DATE: January 17, 2018
PROJECT: Marina Village MS
RE: PR #01R Science classrooms & Science Prep Mods

JOB #1725

LABOR

10 hrs. @ 120.87/hr.		1208.70
	Total labor	1208.70

MATERIAL

(2) Haws Model 7610 Eye wash @ 407.10		814.20
(1) Refrig. icemaker Guy Gray Model SSIB2AB @ 112.27/ea.		112.27
(2) Brasscraft angle stops @ 7.30/ea.		14.60
(2) Brasscraft 23" SS flex @ 5.00/ea.		10.00
(2) 1/2 x 6 brass nipple @ 6.55/ea.		13.10
Misc. 1/2" copper pipe & fittings		40.00
	Subtotal material	1004.17
	Sales tax @ 7.75%	77.82
	15% Profit & Overhead	162.30
	Material total	1244.29
	Labor & material	2452.99



9823 Old Winery Place, Ste. 20
Sacramento, CA 95827
Office: 916.853.0514
Fax: 916.853.0515

CSLB # 418113

www.wwfcontractors.com



License #931227
 4001 Uniontown Rd.
 Lotus, CA 95651
 Ph: (530) 919-2104
 Fax: (530) 621-0381
 john@grecomechanical.com
 www.grecomechanical.com

CHANGE ORDER REQUEST

To: Carter Kelly, Inc.
 P.O. Box 1477
 171 Middletown Road
 Placerville, CA 95667

Order No. 4
 Date: 11/6/2017
 Job No: 190

Attn: Carl Dingle

Project: Marina Village MS Portable Replacement 2017

Ref: PR01 CO

Quantity	Item	Unit Cost	Total
1	ADD: PR01 changes to mechanical scope. (3) Ceilingexhaust fans, grills louvers, ducting & 2" stainless steel exhaust vent chemical cabinet. Material:	\$2,500.00	\$2,500.00
	Labor: 22Hrs/ 106.31	\$2,338.82	\$2,338.82
		Sub total:	\$4,838.82
		15% O/P	\$725.82
		Total	\$5,564.64



ALLEN'S

CABINET & FIXTURE, INC.

CALIFORNIA CERTIFIED SMALL BUSINESS #48288
 WOODWORK INSTITUTE CERTIFIED LIC.#778
 CONTRACTOR'S LIC. #719680

November 29, 2017

Carter Kelly, Inc.
 P.O. Box 1477
 Placerville, CA 95667

Attn: Carl Dingle
 Re: Elevation changes to casework for the Marina Village Middle School.

Carl,

Please find below itemized cost changes for the above reference project.
 All pricing includes adds/deducts for sales tax, delivery and install.

Room #D103 & D105-

Add plastic laminate tall storage cabinet with locks- ADD- \$2,630.00

Room #D103 & 105-

On north, south, east and west elevations, convert

2-ea. drawer bank configurations to standard drawer

Door cabinets- DEDUCT- (\$1,575.00)

Omit all glass doors and provide standard PL door slab-
 DEDUCT- (\$4,485.00)

Room #D104-

Omit all glass doors and provide standard PL door slab- DEDUCT- (\$1,430.00)

Omit 6'-8" of base cabinet- DEDUCT- (\$525.00)

Please Note: In Room #D104 lower base re-configuration will result in a no-cost change.

Added cost associated with above change-	\$2,630.00
<u>Deducted cost associated with above changes-</u>	<u>(\$8,015.00)</u>
TOTAL DEDECT =	(\$5,385.00)

Please call with any questions.

Sincerely,

Daniel Allen
 Vice President

Alessandro

ELECTRIC INC.

Proposed Change Order

Project: Marina Village

PCO #: 05 R ASI

DATE: 1/22/2018 RFI

The reason for this Change Request is: (check one and fill in the blanks)

This responds to a CM-issued Change Order Request

PR#01R

Scope has changed due to a response to Request for Information (RFI) #

OTHER: _____

DESCRIPTION OF CHANGE:

- 1) Add 120V/20A circuit, pathway and disconnects for CEF1-3 from existing spare breaker in panel LD-1M-25.
- 2) Add 120V/20A circuit, pathway and disconnects for Rrig from existing spare breaker in panel LD-1R-24.

Requested Cost Change: \$5,056.00

Requested Schedule Change: Increase / Decrease: 2 calendar days.

Contractor Signature: *Clint Almeida* Date: 1/22/2018

Accepted
(PCO/WO to follow)

Resubmit per comments
(Use same CR #)

Rejected
(See Comments)



Job ID: JOB-02471
Project: marina village



CO: CO-0005: Added circuits for CEF IWH Frig

Top Sheet Report

22 Jan 2018 11:36:08

Tax Rate status: Default

Bid Name: ADDITIONAL CIRCUITS

Bid Template: BASIC CHANGE ORDER

Description	Column 1	Column 2
DIRECT LABOR HRS	41.90	
DIRECT LABOR DOLLARS		3,602.34
INDIRECT LABOR HRS		
INDIRECT LABOR DOLLARS		
LABOR TAX		
MATERIAL DOLLARS		915.72
QUOTES DOLLARS		
MATERIAL & QUOTE TAX		77.84
DJC		
SUBCONTRACTS TOTAL		
EQUIPMENT TOTAL		
EQUIP/SUBCONTRACT TAX		
OVERHEAD TOTAL		459.59
PROFIT TOTAL		
MISC TOTAL		

Bid Memo:

Bid Total: 5,055.48

Alessandro Electric Inc.

4009 Vista Park Ct,
Sacramento, CA 95834

Phone: 916-283-6966

Web: www.alessandroelectric.com

Job ID: JOB-02471
 Project: marina village



CO: CO-0005: Added circuits for CEF IWH Frig

Summary by Item Number

22 Jan 2018 11:37:03

Item #	Size	Description	Q/M	Quantity	U/M	Mat Unit	Mat Result	Labor Unit	Lab Result
10047	3/4	EMT	M	200	FT	1.8700	374.00	0.0465	9.30
30178	3/4	EMT STEEL-COMP COUPLING	M	20	EA	4.1218	82.44	0.2790	5.58
30278	3/4	EMT STEEL COMP IN-THROAT CONN	M	8	EA	4.5792	36.63	0.1400	1.12
40172	1/2	PLASTIC BUSHING	M	6	EA	0.5574	3.34	0.1500	0.90
50006	1/2	FLEXIBLE STEEL CONDUIT	M	18	FT	0.7600	13.68	0.0400	0.72
50028	1/2	FLEX COND ANGLE CONN	M	3	EA	4.9316	14.79	0.1440	0.43
50039	1/2	FLEX COND STRAIGHT CONN	M	3	EA	1.2955	3.89	0.1200	0.36
60001	1/2	BUSHED CHASE NIPPLE-STEEL	M	3	EA	1.3386	4.02	0.1200	0.36
70037	12	THHN/THWN CU (STR)	M	708	FT	0.1652	116.95	0.0056	3.98
70145	12.	GREEN THHN CU (GRD 20A)	M	244	FT	0.1652	40.30	0.0055	1.33
100092	#18 to 10	WIRE-NUT SML -YELLOW	M	12	EA	0.1319	1.58	0.0300	0.36
100104		GROUND SCREW	M	3	EA	0.0633	0.19	0.0400	0.12
100107	#12	PIGTAIL W/GRD SCREW	M	1	EA	0.7562	0.76	0.0400	0.04
100121	18-12	PSH-IN 4-WIRE CONN	M	1	EA	0.1418	0.14	0.0390	0.04
140033	20A 2P3W	SGL RECPT 125V N5-20R SPEC- GRADE	M	1	EA	15.0450	15.05	0.3000	0.30
140269	20A	1P TOGGLE COMMERCIAL -GRADE	M	3	EA	5.4884	16.47	0.2500	0.75
140513	15>20A 1.4 DIA HOLE	1G S-STL SGL RECEIPT PLATE	M	1	EA	2.2358	2.24	0.1000	0.10
140569		1G WP SWITCH PLATE	M	3	EA	13.2710	39.81	0.2000	0.60
150004	1-1/2"D 21.0-CI	4"SQ 1/2- KO NO BRKT	M	3	EA	12.2292	36.69	0.3000	0.90
150015	1-1/2"D 21.0-CI	4"SQ CMB- KO FM- BRKT	M	1	EA	16.5469	16.55	0.3000	0.30
150060	5/8"RISE 4.8-CI	1G 4"SQ PLASTER-RING	M	1	EA	7.9133	7.91	0.1500	0.15
150092		4"SQ BLANK CVR	M	3	EA	4.6105	13.83	0.0800	0.24
150444	2" DEEP 16.5-CI	1G ALUM WP (BELL) BOX W/ 3 x 1/2"HUBS	M	3	EA	13.7365	41.21	0.6000	1.80
160200	1/4"	FLAT WASHER (PLT)	M	6	EA	0.0439	0.26	0.0012	0.01
160595	#10 x 1"	TEK SCREW	M	6	EA	0.1395	0.84	0.0240	0.14
160602	#10 x 1"	SHEET METAL SCREW	M	26	EA	0.1457	3.79	0.0240	0.62
160603	#12 x 1"	SHEET METAL SCREW	M	18	EA	0.0600	1.08	0.0300	0.54
160822	1/2	EMT 1-HOLE STEEL STRAP	M	6	EA	0.6983	4.19	0.0400	0.24
160823	3/4	EMT 1-HOLE STEEL STRAP	M	13	EA	0.9334	12.13	0.0400	0.52

Alessandro Electric Inc.

4009 Vista Park Ct.
 Sacramento, CA 95834

Phone: 916-283-6966

Web: www.alessandroelectric.com

Item #	Size	Description	Q/M	Quantity	U/M	Mat Unit	Mat Result	Labor Unit	Lab Result
160843	3/4	EMT 2-HOLE STEEL STRAP	M	12	EA	0.6180	7.42	0.0450	0.54
210051		ROOF-TOP EXHAUST FAN CONNECTION	M	3	EA	0.0000	0.00	3.0000	9.00
630090	1/2 3/4 or AC/MC	EMT PUSH-IN SCREW MOUNT 1-1/2 DEEP BOX	M	2	EA	1.7741	3.55	0.2500	0.50
Phase/Group totals:							915.72		41.90
Job totals:							915.72		41.90

Carter-Kelly, Inc.

CHANGE ORDER

No. 00015

P.O. Box 1477
Placerville, CA 95667

Phone: 530-621-0950
Fax: 530-621-2344

TITLE: Owner CO15 Fire alarm change
PROJECT: Marina Village Portable Replacement

DATE: 03/07/2018
JOB:

TO: Attn: Phil Jones
Rescue Union School District
2390 Bass Lake Road
Rescue, CA 95672

CONTRACT NO: 26

Phone: 530-672-4302 Fax: 530-677-5182

Item	Description	Stock#	Quantity	Units	Unit Price	Tax Rate	Tax Amount	Net Amount
00001	District request to change the fire alarm system from Simplex to Silent Knight, resulted in a credit. It still needs to be determined how the new system will interface with the existing campus Simplex system.		1.000		(\$5,734.00)	0.00%	\$0.00	(\$5,734.00)

Unit Cost: (\$5,734.00)
Unit Tax: \$0.00
Total: (\$5,734.00)

The Original Contract Sum was	\$7,231,894.00
Net Change by Previously Authorized Requests and Changes	\$302,083.00
The Contract Sum Prior to This Change Order was	\$7,533,977.00
The Contract Sum Will be Decreased	\$5,734.00
The New Contract Sum Including This Change Order	\$7,528,243.00
The Contract Time Will Not be Changed	
The Date of Substantial Completion as of this Change Order Therefore is	

ACCEPTED:

Rescue Union School District

Carter-Kelly, Inc.

CALIFORNIA DESIGN WEST

By: _____
Phil Jones

By: 
Matt Vanderpool

By: 
Mitch McAllister

Date: 03/07/2018

Date: 03/07/2018

Date: 03/07/2018

CONTRACTOR PROPOSAL – COST BREAKDOWN

California Design West
 Marina Village
 Date: 3/5/18



DESCRIPTION OF WORK: District request to change from Simplex fire alarm system to Silent Knight fire alarm system for Building D. COR includes a credit from Simplex and an add for the the new Silent Knight fire alarm system. Please note that Simplex has been unresponsive on the credit they are issuing, so the credit included in the attached backup is the remaining balance of their contract that has been billed to date. We reserve the right to issue a future change order as necessary if a dispute should arise as to the amount of the credit that Simplex issues.

I. CKI LABOR	RATE	HOUR(S)	\$ AMOUNT
CLASSIFICATION			
Superintendent -	93		\$0
Carpenters / Cement Masons	91		\$0
Laborer	85		\$0
TOTAL DIRECT LABOR			\$0
OVERHEAD PROFIT/FEE@		15%	\$0
TOTAL FOR LABOR			\$0

II. CKI MATERIAL	QUANTITY	UNIT PRICE	\$ AMOUNT
TOTAL DIRECT MATERIAL			\$0
OVERHEAD PROFIT/FEE@		10%	\$0
TOTAL FOR MATERIAL			\$0

III. CKI EQUIPMENT	RATE	Months	\$ AMOUNT
TOTAL DIRECT EQUIPMENT			\$0
OVERHEAD PROFIT/FEE@		10%	\$0
TOTAL FOR EQUIPMENT			\$0

IV. SUBCONTRACTORS	\$ AMOUNT	
Alessandro Electric	-\$5,461	
TOTAL DIRECT SUBCONTRACTOR		-\$5,461
OVERHEAD PROFIT/FEE@		5% (\$273)
TOTAL FOR SUBCONTRACTOR		-\$5,734

COST PROPOSAL TOTAL **-\$5,734**

COMPANY: Carter-Kelly, Inc SIGNATURE: *[Signature]*
 PRINT NAME: Matt Vanderpool TITLE: Project Manager

Alessandro

ELECTRIC INC.

Proposed Change Order			
Project: Marina Village	PCO #:	10	ASI
	DATE:	3/2/20108	RFI

The reason for this Change Request is: (check one and fill in the blanks)

This responds to a CM-issued Change Order Request

Scope has changed due to a response to Request for Information (RFI) #

OTHER: Email request from Carter Kelly

DESCRIPTION OF CHANGE:

Provide credit for remain portion of Simplex fire alarm system scope.
 At the time this cost proposal was presented to Carter Kelly, SimplexGrinnell had not provided any information to support additional cost to date, over and above what SimplexGrinnell had billed to date even after being asked to provide the information 6 times over a time period of 30 days. AEI reserves the right to alter the below cost if Simplex Grinnell can support a claim that they have additional cost over and above what they have billed for.

Provide cost for Silent Knight fire alarm system in Building D. Excluding programming and connections to tie into existitng Simplex fire alarm panel.

Requested Fire Alarm System Credit:	<u>(\$39,521.00)</u>
Requested Cost for Silent Knight Fire Alarm System	<u>\$34,060.00</u>
Combined Change	<u>(\$5,461.00)</u>

Contractor Signature: *Clint Alessandro* Date: 3/2/20108

Accepted (PCO/WO to follow) Resubmit per comments (Use same CR #) Rejected (See Comments)



Matt Vanderpool

From: Anne Perkins <aperkins@ca-dw.com>
Sent: Monday, March 05, 2018 1:31 PM
To: Matt Vanderpool
Cc: Mike Swars; Robyn Kelly; Garret Feasel; Mitch Mcallister
Subject: FW: FW: Marina Village - Fire alarm changes - cost proposal

Hi Matt,

Per District direction, please proceed with the cost proposal for the FA changes. Please also prep a CO for signature and I will circulate to all parties.

Thank you,

Anne Perkins
California Design West Architects
2100 19th Street
Sacramento, CA 95818
916.446.2466
www.ca-dw.com

From: Philip Jones [mailto:pjones@my.rescueusd.org]
Sent: Monday, March 05, 2018 1:27 PM
To: Anne Perkins <aperkins@ca-dw.com>
Cc: Sean Martin <smartin@rescueusd.org>; Mitch Mcallister <mmcallister@ca-dw.com>; Garret Feasel <gfeasel@ca-dw.com>
Subject: Re: FW: Marina Village - Fire alarm changes - cost proposal

Looks good Anne,

Please proceed with the CO,

thanks,

-Phil

On Mon, Mar 5, 2018 at 10:44 AM, Anne Perkins <aperkins@ca-dw.com> wrote:

Good Morning Phil and Sean,

Please see attached cost changes (deduct) for the requested Fire Alarm system changes. Mitch has reviewed and said these numbers are right where we expected them to be. If this pricing is acceptable, please let me know and I will have CKI prep a CO for this work.

Thank you,

Anne Perkins

California Design West Architects

2100 19th Street

Sacramento, CA 95818

916.446.2466

www.ca-dw.com

From: Matt Vanderpool [mailto:mattv@carterkelly.com]

Sent: Monday, March 05, 2018 10:12 AM

To: Anne Perkins <aperkins@ca-dw.com>; Garret Feasel <gfeasel@ca-dw.com>

Subject: Fire alarm changes - cost proposal

Anne/Garret

Please see the attached cost proposal for the fire alarm system changes and let me know if you have any questions.

Thank you,

Matt Vanderpool
LEED® AP / DBIA

Carter-Kelly, Inc.
P.O. Box 1477
Placerville, California 95667

Work: 530-621-0950
Mobile: 916-825-1088
Fax: 530-621-2344
Email: mattv@carterkelly.com
CKI Online

--
Philip Jones

Maintenance & Operations Coordinator

Rescue Union School District

2460 White Oak Road

Rescue, CA 95672

Phone: (530) 672-4300

Fax: (530) 677-5182

www.rescueusd.org



(530) 621-0950
P.O. Box 1477 • Placerville, CA 95667
Contractors License #407415

February 26, 2018

Mitch McAllister

Re: MARINA Village PR #17

This is a no cost proposal request, the door; frame and hardware have already been purchased and will be turn over to the district. The door frame needs to be removed and opening framed. This cost will be offset by labor needed to hang door and set hardware, cost for wall finish will be offset by painting cost of door frame and signage.

Sincerely, Carl Dingle

Carl Dingle

"BUILDING RELATIONSHIPS ON A FOUNDATION OF INTEGRITY"



PROPOSAL REQUEST

CALIFORNIA DESIGN WEST ARCHITECTS INC.

2100 19TH STREET | SACRAMENTO CA 95818 | 916.446.2466 | WWW.CA-DW.COM

PROJECT:
Marina Village MS – Portable Classroom Replacement
DSA App # 02-115519; DSA File # 9-45

PROPOSAL REQUEST NO.: 17
DATE OF ISSUANCE: 02/23/18

OWNER:
Rescue Union School District
2390 Bass Lake Road
Rescue, CA 95370

CONTRACTOR:
Carter-Kelly, Inc.
P.O. Box 1477
Placerville, CA 95667

PLEASE SUBMIT AN ITEMIZED QUOTATION FOR CHANGES IN THE CONTRACT SUM AND/OR TIME INCIDENTAL TO PROPOSED MODIFICATIONS TO THE CONTRACT DOCUMENTS DESCRIBED HEREIN. THIS IS NOT A CHANGE ORDER NOR A DIRECTION TO PROCEED WITH THE WORK DESCRIBED HEREIN.

**DOOR D208B BETWEEN ROOM D207 AND ROOM D208 –
PROVIDE A CREDIT TO REMOVE DOOR D208B BETWEEN CLASSROOMS D207 AND D208
AS WELL AS ALL ASSOCIATED HARDWARE AND SINGAGE. INFILL DOOR OPENEING WITH
FRAMING AND FINSISH TO MATCH ADFJACENT WALL.**

ATTACHMENTS:

REQUESTED BY:

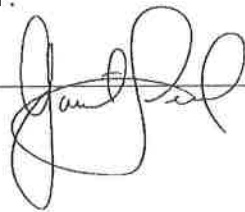
Signature 

Garret Feasel
Name

RESCUE UNION SCHOOL DISTRICT

AGENDA ITEM: **Resolution #18-09**
Declaring an Election Be Held in RUSD Jurisdiction
Consolidation with Other Districts Requesting Election Services

BACKGROUND:

Education Code 5000.5 requires the Board to order a regular biannual election to fill offices of members of the Governing Board. The Board is also required to pass a resolution requesting to have the election consolidated with any other election conducted on the same day.

STATUS:

Three full terms to expire 12/2/2022 are up for election on Tuesday, November 6, 2018. Resolution #18-09 calls for consolidation of the election with other districts requesting election services.

FISCAL IMPACT:

Resolution #18-09 authorizes the Registrar of Voters, at District expense, to provide all necessary services, which shall include, but not be limited to: publications, issue nomination documents, ballots, sample ballots, election officers, polling places and canvass.

RECOMMENDATION:

District administration recommends the Board approve Resolution #18-09 to consolidate the election held in its jurisdiction with other districts requesting election services.

RESOLUTION NO. 18-09

Rescue Union School District

Declaring an Election Be Held in its Jurisdiction
Consolidation with Other Districts
Requesting Election Services

WHEREAS, it is the determination of the above-named district that an election be held on November 6, 2018, at which election the issue to be presented to the voters shall be:

NOMINATION OF CANDIDATES

No. of Members	
<u>To be Elected</u>	<u>Term</u>
3	Full 4 year terms to expire 12/02/2022

BE IT RESOLVED that the Elections Department of El Dorado County is hereby requested to:

1. Consolidate said election with any other election conducted on the same day.
2. Authorize and direct the Registrar of Voters, at District expense, to provide all necessary services, which shall include, **but not be limited to:**

publications, issue nomination documents, ballots, sample ballots, election officers, polling places and canvass.
3. In the event of a tie vote, the winning candidate shall be decided by lot.

PASSED AND ADOPTED on _____, 2018 at a regular meeting, by the following vote:

AYES:
NOES:
ABSENT:

President

ATTEST: _____

Date: _____

RESCUE UNION SCHOOL DISTRICT

AGENDA ITEM: Williams Act Uniform Complaint Procedures Quarterly Report

BACKGROUND:

In order to participate in the School Facilities Program and /or the Deferred Maintenance Program, districts must use the Uniform Complaint Process to identify and resolve any deficiencies related to instructional materials, emergency or urgent facilities conditions, and teacher vacancies or misassignments. Title 5, Chapter 5.1, Section 4600 requires school districts to report summarized data from the Uniform Complaint Process to the county superintendent quarterly.

STATUS:

In January of 2005 the District posted a notice in each classroom-notifying parents that there should be sufficient textbooks and instructional materials in the room and school facilities must be clean, safe and maintained in good repair. The District has adopted a Uniform Complaint Procedure and is now reporting to the County Superintendent pursuant to Education Code 35186, that the Rescue Union School District received no complaints under the Williams Act Uniform Complaint Procedures for the period of January 1, 2018 to March 31, 2018.

FISCAL IMPACT:

The State Allocation Board administers the School Facilities Needs Assessment Grant Program which provides emergency repair monies to pay for “emergency facilities needs”, but are only available to school districts that ranked in deciles 1 to 3, inclusive, based on the 2003 Academic Performance Index. All of the schools in RUSD are above deciles 1 to 3 and do not qualify for the Grant funding.

BOARD GOALS:

Board Focus Goal V – FACILITY HOUSING:

Build, improve and maintain school facilities to meet current and future education needs while integrating the most efficient use of resources.

RECOMMENDATION:

Approve the Williams Act Quarterly Report and direct staff to forward the Williams Act Quarterly report for the period of January 1, 2018 to March 31, 2018 to the El Dorado County Superintendent of Schools.

Quarterly Report on Williams Uniform Complaints

[Education Code § 35186]

To: **Ed Manansala, Ed.D., County Superintendent**

District: **RESCUE UNION SCHOOL DISTRICT**

Person completing this form: **Phil Jones**

Title: **Maintenance/Operations Coordinator**

Quarterly Report Submission Date:
(*check one*)

- April 2018
 July 2018
 October 2018
 January 2019

Date for information to be reported publicly at governing board meeting: **April 10, 2018**

Please check the box that applies:

- No complaints were filed with any school in the district during the quarter indicated above.
- Complaints were filed with schools in the district during the quarter indicated above. The following chart summarizes the nature and resolution of these complaints.

General Subject Area	Total # of Complaints	# Resolved	# Unresolved
Textbooks and Instructional Materials	-0-		
Teacher Vacancy or Misassignment	-0-		
Facilities Conditions	-0-		
TOTALS	-0-		

Signature of District Superintendent

April 10, 2018
Date